

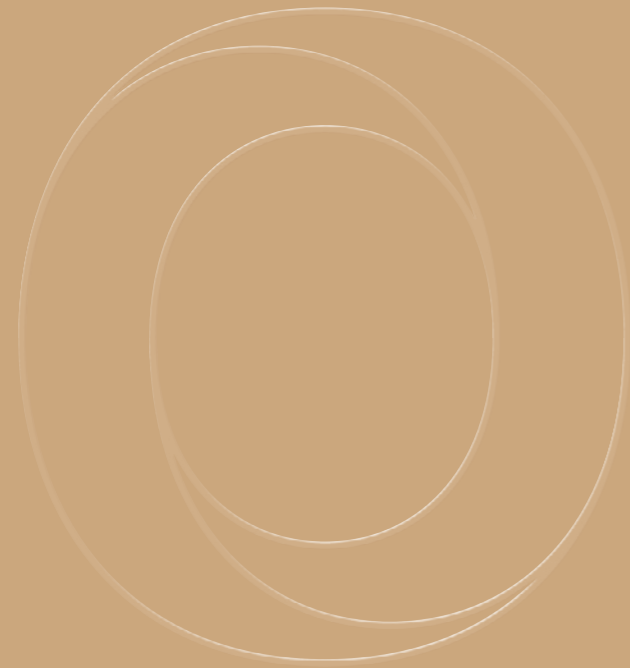

Occhio

Coro & Coro moon



light
my
soul

LIGHT MY SOUL

My process is fluid.
It's a journey. Always seeking,
always exploring.
It starts with a glance. A shift
in light. Attention to detail.
Light is my compass to clarity.

David Kosock is an interior designer. Inspired by nature, he curates materials, colors, and objects. The light of Coro and Coro moon gives him focus on what truly matters – precise and clear.







Coro moon

Light beyond imagination

Coro moon combines a clear, minimalist design language with fascinating innovations. The comprehensive spotlight and luminaire series features the groundbreaking **Occhio fireball** light source, which combines powerful, directed light with soft ambient light.

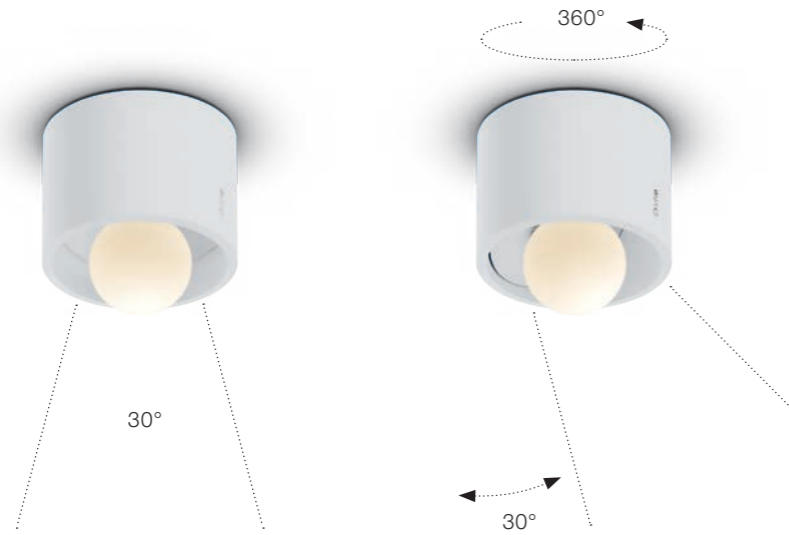

Whether recessed or surface-mounted spotlights, whether swivelling or as a downlight, the Occhio fireball always remains in the centre, but the light is directed wherever it is needed.

Coro moon alto flat spotlight



Coro moon piano pure spotlight



Coro moon spider 9

Coro moon uses the full power of the innovative Occhio fireball technology. From the cool glow of a moonlight to a warm ambience – you can change the lighting mood according to the situation using »**touchless control**« or Occhio air.



Pure innovation – sensors on the side of the luminaire let you become the master of light.

The ideal light for every mood, situation and time of day. Thanks to the built-in »**color tune**« feature, you can choose the appropriate color temperature for every moment – from cool, stimulating light similar to daylight, to warmer color temperatures for a relaxed ambience.



»color tune« – always the mood you want. Change the color temperature to suit the situation via gesture or Occhio air. Optionally, the luminaires are also available in the »x-tra warm« color spectrum (2200–3500K).





Spectacular as an ensemble – Coro moon suspended luminaires become stunning light installations for different table settings when arranged as a ‘cloud’ or ‘spider’. By **synchronising the luminaires**, you can coordinate the light in a fascinating way – by gesture at one of the luminaires or by using the Occhio air app.

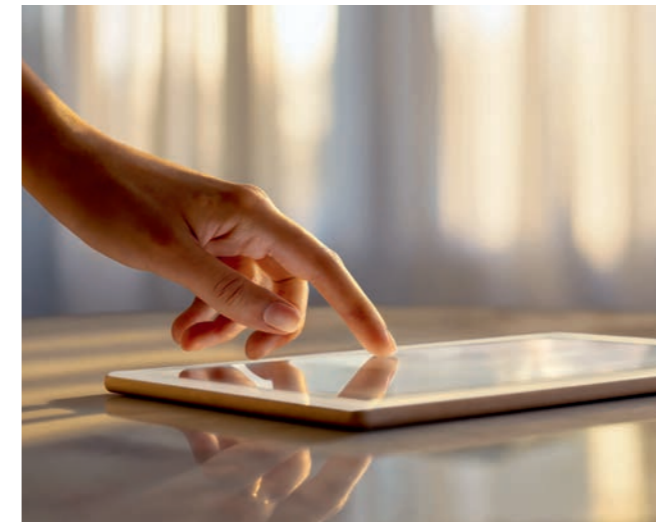

Occhio air allows you to store lighting scenes that you have created and retrieve them at any time with the Occhio air app or the Occhio air controller.

Coro moon vivo stages the **Occhio fireball** like a floating light object. The gleaming disc reflects its presence and amplifies the atmospheric effect – an elegant highlight that draws the eye and playfully refines ceiling surfaces.



Available as a flat version for recessed ceiling mounting or as an up version for surface mounting on the ceiling, the luminaire provides a soft, glare-free lighting effect with directional downward light.



Coro moon vivo up / flat
Expected to be available from spring 2026



Coro moon zero v



Coro moon alto flat spotlight



Coro moon piano pure spotlight



Coro

Minimalism redefined



Zoom optics – for the perfect focus.

With Coro, Occhio takes purism to an extreme: Coro completes the product portfolio with slim, delicate suspended luminaires and innovative recessed and surface-mounted spotlights. Coro luminaires and spotlights have a **zoom optic** to enable lighting perfection. The lenses are characteristic of Occhio, providing glare-free, focussed light.



Coro has been meticulously designed down to the last detail and is available in selected **recessed and surface-mounted versions**. The versions with swivel, 360° rotation and zoom optics can be flexibly adjusted – for targeted accentuation or wide-area lighting.



Coro alto up spotlight
Coro piano cover spotlight
Coro zero v



Coro alto up spotlight
Gioia equilibrio

The minimalist design of Coro spotlights offers powerful features and fascinating lighting effects – and proves that less really can be more. A special highlight: all of the spotlights feature »**color tune**«, so you can adjust the color temperature to suit the situation.



The latest lighting technology combines zoom optics with »color tune« options, so you can adjust the color temperature to suit the situation. Optionally also available as »x-tra warm« with a color spectrum of 2200–3500 K.

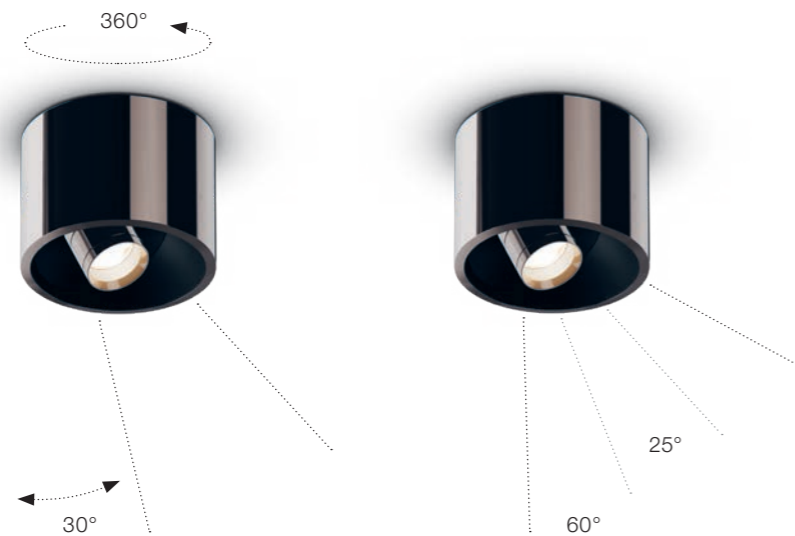

All of the recessed and surface-mounted spotlights can swivel up to 30° and rotate 360°. Their zoom optics enable beam angles of 25°–60°.

The recessed and surface-mounted spotlights in the Coro series offer impressive possibilities for lighting design – with fixed lens optics (downlights) and a **swivelling zoom** (spotlights).

Coro alto flat spotlight

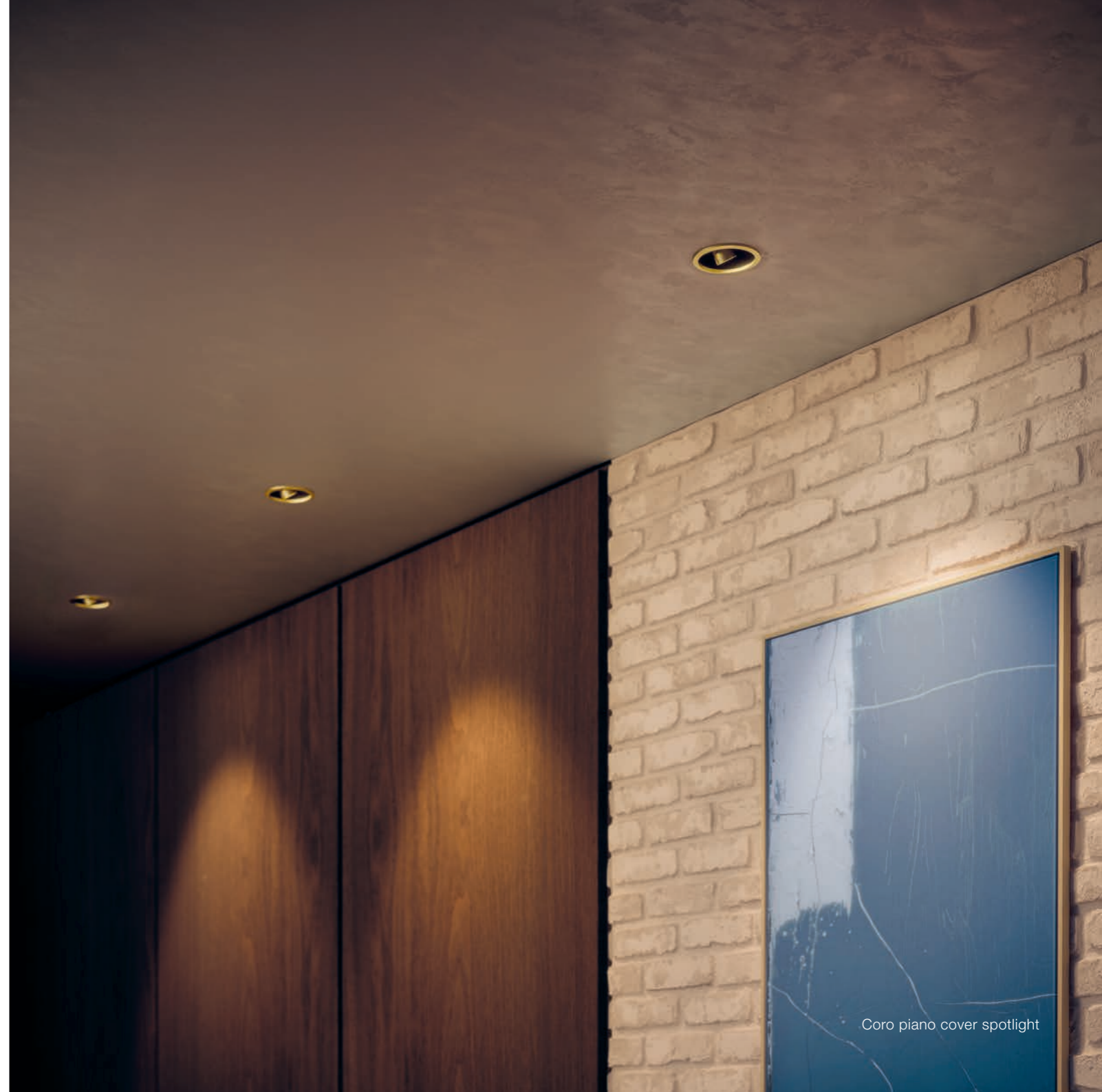

Coro piano cover spotlight



Light, design, and technology merge into an unprecedented experience. With the unique features of Coro and Coro moon, you can orchestrate the light and become the creator of your living space.

Coro & Coro moon Features

Occhio air

Adjust the ambience of your rooms with just a touch. Whether switching on or off, dimming, fading, or creating whole lighting scenes and groups – Occhio air allows you to customise your atmosphere and change it at any time.



Occhio fireball

With Coro moon, the innovative Occhio fireball technology provides powerful focussed light with soft, atmospheric ambient light. A special highlight with recessed or surface-mounted spotlights: the Occhio fireball always remains in the centre, but the light is directed wherever it is needed.

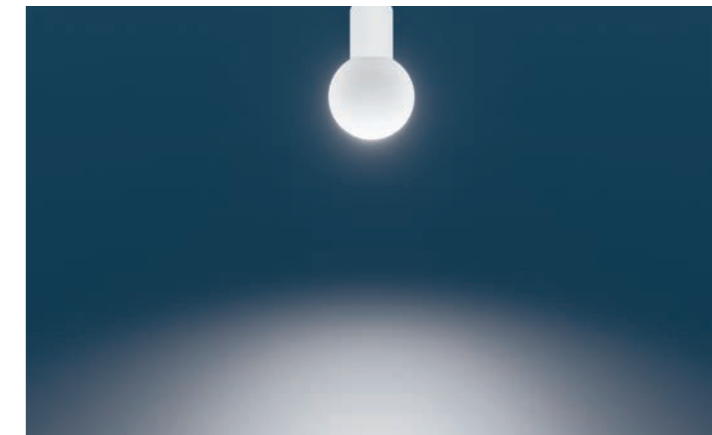

»touchless control«

Using gesture control, a luminaire can be controlled touchlessly via sensors. This enables a synchronous response of whole luminaire groups.



»color tune«

Via gesture control or Occhio air, you can use »color tune« to decide which color temperature is best suited to the current situation – from warm color temperatures for relaxed evening hours to stimulating, cool daylight.

Swivelling and rotating capability

The design of Coro & Coro moon is very reduced, but there is still room for sophisticated technology: the spotlights rotate 360° and swivel up to 30°.

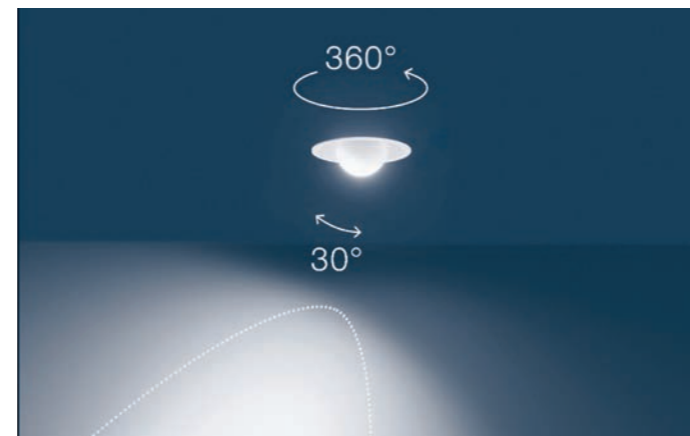

Zoom optic

Coro luminaires and spotlights have zoom optics with continuously adjustable beam angles for perfect lighting effects. Typical Occhio lenses provide glare-free, focussed light.



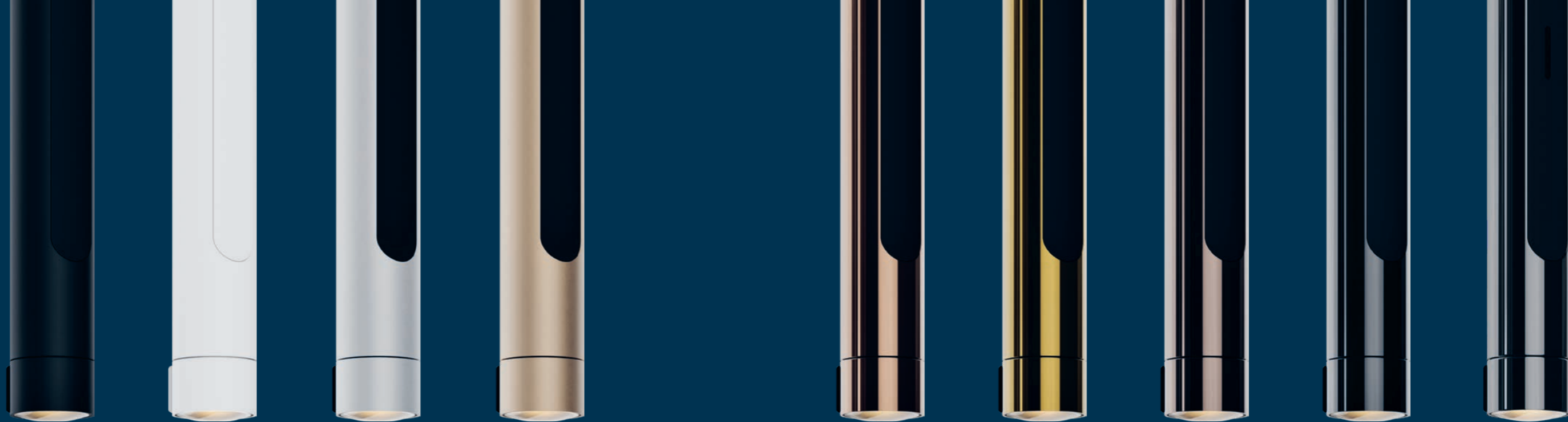

Coro & Coro moon colors

black matt
white matt
silver matt
gold matt

Coro & Coro moon surfaces

rose gold*
gold*
phantom*
black phantom
dark chrome*

Product overview Coro moon



Coro moon sospeso^{1,2}
(up var*, up, flat, pure)
fireball | 6 W | 540 lm

*Stepless height adjustment

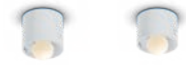

Coro moon alto³
spotlight (up, flat)
fireball | 9 W | 820 lm



Coro moon vivo
downlight (up, flat)
fireball | 9 W | 820 lm

Available in soft bronze, phantom, dark chrome
Expected to be available from spring 2026



Coro moon cloud 3¹
ø 40 cm



Coro moon cloud 5¹
ø 50 cm

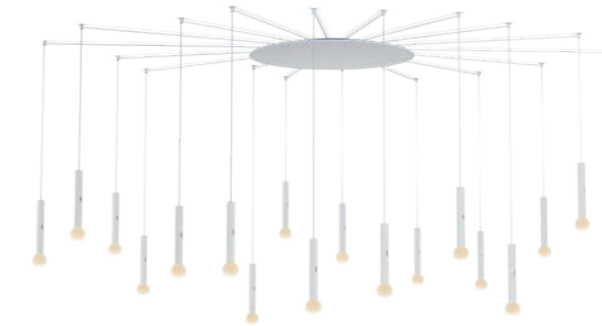

Coro moon spider¹
6–9 heads or 12–18 heads,
Can be arranged individually on request

The luminaires can be synchronised via Occhio air – each luminaire controls the whole cloud.



Coro moon piano³
spotlight (cover, edge, pure)
Cut out ø 92 mm
Mounting height 80 mm
fireball | 9 W | 820 lm



Coro moon piano v
downlight (cover, edge, pure)
Cut out ø 92 mm
Mounting height 80 mm
fireball | 9 W | 820 lm



Coro moon zero v
downlight
Cut out ø 26 mm
Mounting height 90 mm
fireball | 7 W | 680 lm

Features: Occhio fireball | »color tune« 2700 K–4000 K | »x-tra warm« 2200 K–3500 K (optional) | Occhio air (optional)

¹»touchless control« | ²Height adjustment (optional) | ³Rotation and swivelling (30° and 360°)



The Coro moon series is also available as pro versions without integrated electronics for operation with standard external ballasts (constant current) – ideal for lighting concepts in projects.

Product overview Coro



Coro sospeso^{1,2}
(up var*, up, flat, pure)
zoom | 6 W | 320 lm

*Stepless height adjustment



Coro alto³
spotlight (up, flat)
zoom | 9 W | 540 lm



Coro cloud 3¹
ø 40 cm



Coro cloud 5¹
ø 50 cm



Coro piano³
spotlight (cover, edge, pure)
Cut out ø 92 mm
Mounting height 80 mm
zoom | 9 W | 540 lm



Coro piano v
downlight (cover, edge, pure)
Cut out ø 92 mm
Mounting height 80 mm
S 60 | 9 W | 520 lm



Coro zero v
downlight
Cut out ø 32 mm
Mounting height 90 mm
S 60 | 7 W | 480 lm

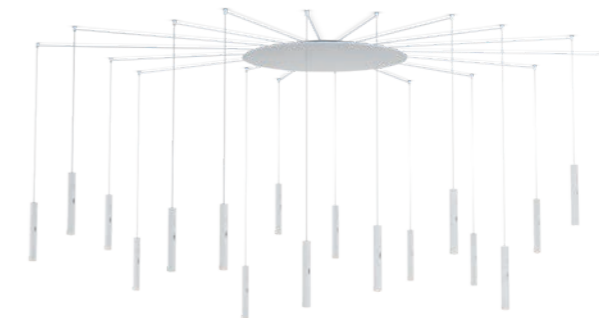

Coro spider¹
6–9 heads or 12–18 heads,
Can be arranged individually on request

The luminaires can be synchronised via Occhio air – each luminaire controls the whole cloud.

Features: fixed lens optics or a swivelling zoom | »color tune« 2700 K–4000 K | »x-tra warm« 2200 K–3500 K (optional)
Occhio air (optional) | ¹»touchless control« | ²Height adjustment (optional) | ³Rotation and swivelling (30° and 360°)



The Coro series is also available as pro versions without integrated electronics for operation with standard external ballasts (constant current) – ideal for lighting concepts in projects.

Imprint

Editor

Occhio GmbH
Wiener Platz 7
D-81667 München
Tel +49 89 44 77 86 30
info@occhio.com

Dr. Benno Zerlin
Dr. Oliver Arndt
HRB 133172 / USt-Id DE 813 013 462

Product design

Axel Meise

Concept / Design

Martin et Karczinski
www.martinetkarczinski.de

Renderings / Photos

Chris Faber, www.chrisfaber.studio
sooi GmbH, www.sooii.com
Kolja Eckert, www.koljaeckert.com
Bohman + Sjöstrand Photography, www.bohmansjostrand.com

Print

Druckerei Vogl GmbH & Co KG
Georg-Wimmer-Ring 9, 85604 Zorneding
www.druckerei-vogl.de

English

2025 | 11 – 1st edition
Subject to errors and technical changes.

© Occhio GmbH 2025

occhio.com



occhio.com

Occhio

light my soul