

Occhio

# io verticale pro

Montageanleitung

Mounting instructions

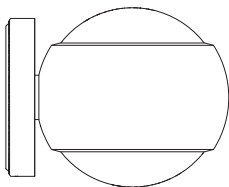



# Inhalt / Contents

Sicherheitshinweise	04	Safety precautions	05
Produktbeschreibung	06	Product description	07
<b>Linse und inserts einsetzen</b>	<b>09</b>	<b>Inserting lens and inserts</b>	<b>09</b>
<b>Montage io verticale pro</b>	<b>15</b>	<b>Mounting io verticale pro</b>	<b>15</b>
up / down zusammen steuern	19	control up / down simultaneously	19
up / down getrennt steuern (optional)	21	control up / down individually (optional)	21
Demontage io verticale pro	25	Remove io verticale pro	25
Steuerung mit der Occhio air App (optional)	29	Control using the Occhio air app (optional)	29
Steuerung mit dem Occhio air controller (optional)	37	Control using the Occhio air controller (optional)	37
Anhang	41	Appendix	41
Pflegehinweise	42	Care instructions	42
Info & Kontakt	43	Information & contact	43
Technische Daten	44	Technical data	45

# Sicherheitshinweise

Lesen Sie die Montage-/Gebrauchsanweisung sorgfältig durch, bevor Sie die Leuchte installieren. Beachten Sie die Sicherheitshinweise in dieser Anleitung genau und bewahren Sie die Anleitung auf.



Dieses Zeichen macht Sie auf eine gefährliche Situation aufmerksam, die eine schwere Verletzung oder den Tod nach sich ziehen kann, wenn sie nicht beachtet wird. Es macht Sie zudem auf mögliche Sachschäden und andere wichtige Informationen in Verbindung mit diesem Produkt aufmerksam.



Die Montage von Elektrokomponenten darf nur von qualifiziertem Fachpersonal durchgeführt werden. Reparaturarbeiten dürfen nur von autorisiertem Fachpersonal oder dem Hersteller durchgeführt werden. Vor allen Arbeiten an der Leuchte (Installation, Reinigung etc.) diese unbedingt vom Stromnetz trennen.



Dieses Zeichen macht Sie auf Situationen aufmerksam, bei denen Sie direkt in das Licht der LED blicken könnten. Dies kann zu Nachbildern und bei längerer Dauer zu Schädigungen der Augen führen.



Sicherheitsabstand zu brennbaren Objekten einhalten: 20 cm!



Dieses Zeichen macht Sie auf heiße Oberflächen aufmerksam, deren Berührung Verbrennungen zur Folge haben können.

**Achtung:** Die Oberfläche der Leuchte kann nach längerer Betriebsdauer heiß sein! Vor allen Arbeiten an der Leuchte (Montage usw.), Leuchte immer ausschalten und mindestens 30 Minuten abkühlen lassen. Nur zur Installation außerhalb des Handbereichs vorgesehen.

## Safety precautions

Read through the mounting/ use instructions carefully before installing the luminaire. Follow the safety precautions in these instructions closely and keep the instructions in a safe place.



This symbol warns you of a dangerous situation which could lead to serious injury or even death if the instructions are not observed. It also draws your attention to possible material damage and provides other important information in connection with this product.



The assembly and installation of electrical components must be carried out only by qualified personnel. Repairs must be carried out only by authorised, qualified personnel or the manufacturer. Before performing any work on the luminaire (installation, cleaning, etc.), it must be disconnected from the mains supply.



This symbol draws your attention to situations in which you could look directly into the light of the LED. This may cause an after-image effect and may result in damage to the eyes if you look at the light directly for prolonged periods.



Maintain the minimum safety distance from flammable materials: 20 cm.



This symbol warns you of hot surfaces, which could cause burns if touched.

Caution: When used for prolonged periods, the surface of the luminaire can become hot. Before performing any work on the luminaire (fitting the luminaire etc.), always switch the luminaire off and let it cool for at least 30 minutes. Only for installing in a position which is out of arm's reach.

# Produktbeschreibung

LED Wandstrahler mit beidseitigem Lichtaustritt, kugelförmigem Kopf und Linsenoptik. Die Leuchte ist frei drehbar (mit Anschlag), die Lichtwirkungen sind durch optionale inserts jederzeit über einen einfachen Mechanismus veränderbar, dichroitische Farbfilter zusätzlich einsetzbar. Oberflächenkombinationen konfigurierbar.

Version für Montage auf Hohlraum- oder Wanddose mit externem Vorschaltgerät, Anschluss an Stromquelle (Treiber). Leistung 18W oder 13W\*, dimmbar bauseits über dimmbares Vorschaltgerät. Occhio light module wechselbar.

Weitere Versionen: io alto v, io giro, io giro doppio, io piano, io piano v

\* Version chrom glanz, rose gold, bronze

## Product description

LED wall spotlight with double-sided light output, spherical head and lens optics. The light is freely rotatable (with stop), the lighting effects can be changed at any time through optional inserts using a simple mechanism, dichroic colour filter can be additionally inserted. Surface combinations can be configured.

Version for fitting on hollow ceiling box or wall box with remote power supply unit; connection to external power source (driver). Power 18 W or 13 W\*; dimmable via customer-supplied dimmable power supply unit. The Occhio light module is replaceable.

Other versions: io alto v, io giro, io giro doppio, io piano, io piano v

\* Version shiny chrome, rose gold, bronze





Linse und  
inserts  
einsetzen

Inserting lens  
and inserts

# Linse und inserts einsetzen

## Inserting lens and inserts

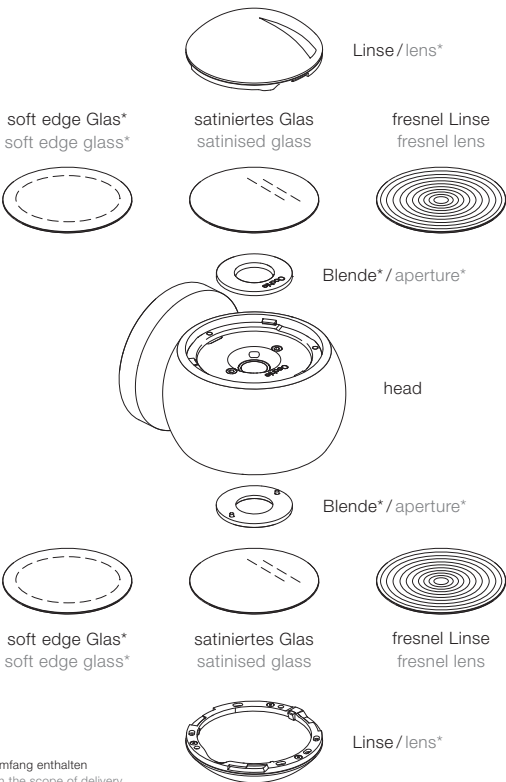

\* Im Lieferumfang enthalten

\* Included in the scope of delivery

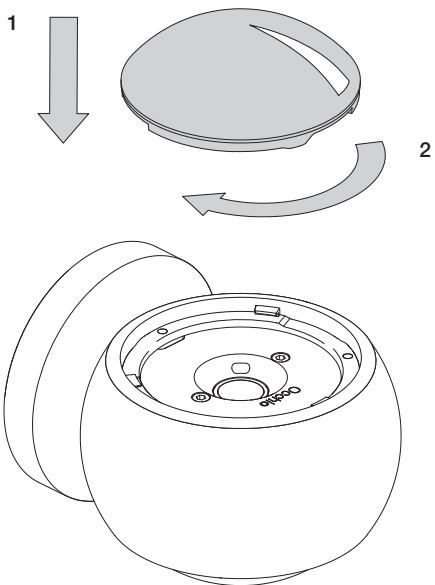

# Inserts einsetzen (optional)

## Inserting inserts (optional)

1

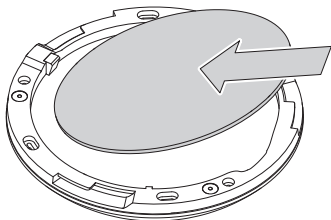

2

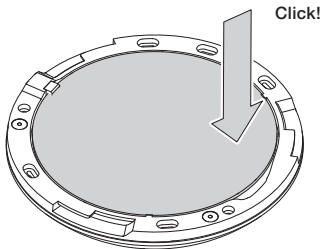

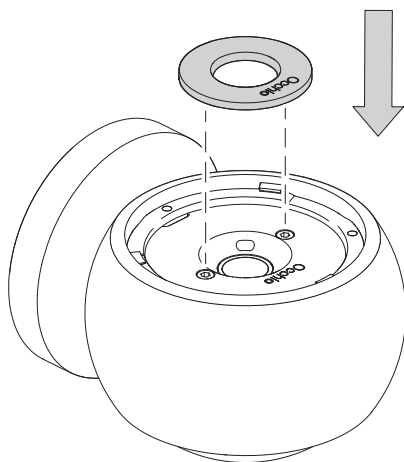

**Blende nur ohne inserts  
verwenden.**



**Use aperture just without  
inserts.**



Montage  
io verticale  
pro

Mounting  
io verticale  
pro

# Montage io verticale pro

## Mounting io verticale pro

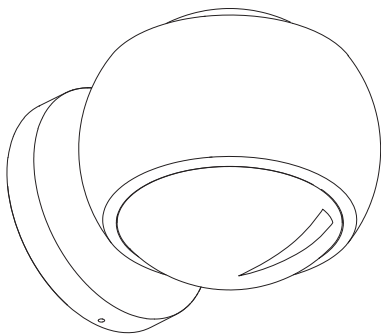





Dübel/  
screw anchor



Montageplatte/  
mounting plate

Schrauben/  
screws

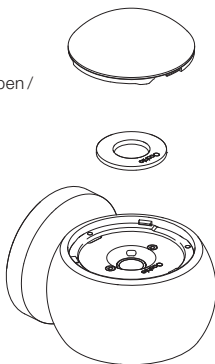

Linse / lens

Blende / aperture

io verticale pro

Blende / aperture

Linse / lens



Occhio release-tool

# Montage io verticale pro

## Mounting io verticale pro

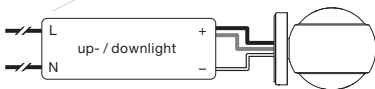

max. 500 mA (max. 350 mA  
chrome, rose gold, bronze)

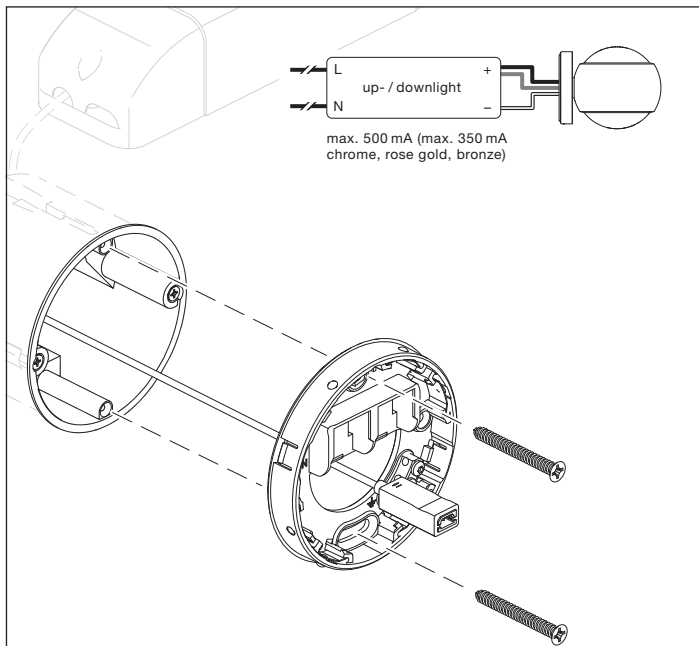

**Vor der Montage alle  
stromführenden Leitungen  
vom Stromnetz trennen!**



**Before mounting, disconnect  
all currentcarrying lines from  
the mains supply!**

up / down zusammen steuern  
control up / down simultaneously

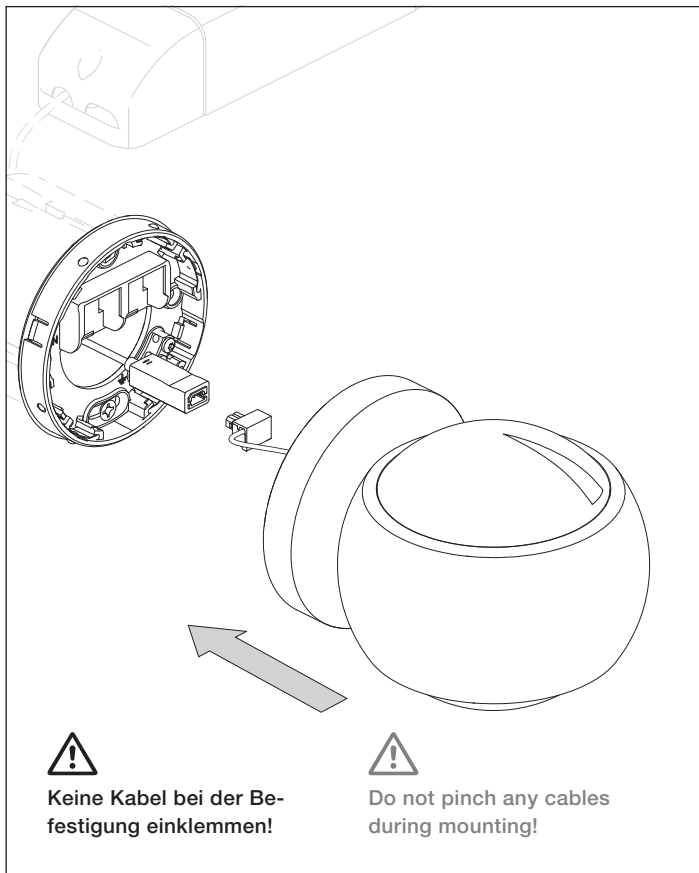

# Montage io verticale pro Mounting io verticale pro

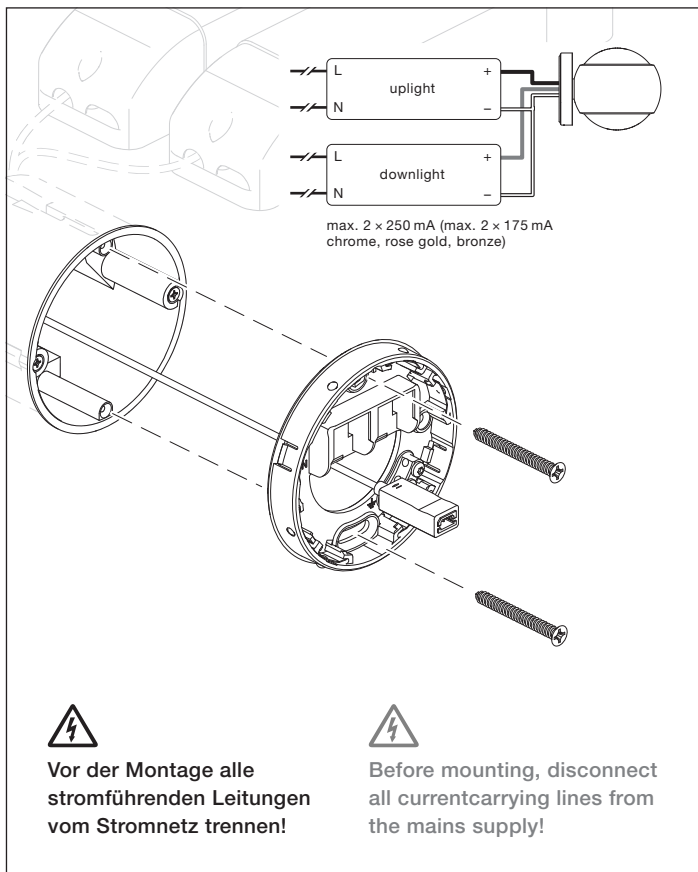

up/down getrennt steuern (optional)  
control up/down individually (optional)

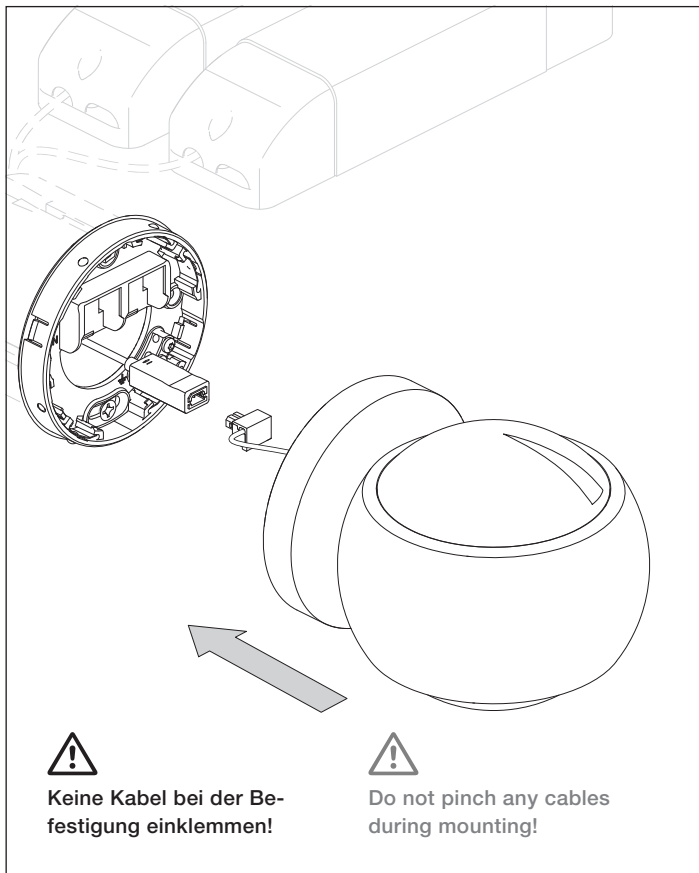

## Montage io verticale pro Mounting io verticale pro

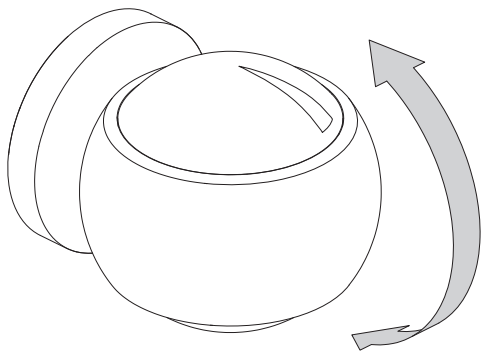

Festen Halt der Leuchte  
überprüfen!

**Die Leuchte ist nun fertig  
montiert.**

Check that the luminaire is held  
in place firmly.

**The luminaire is now fully  
mounted.**

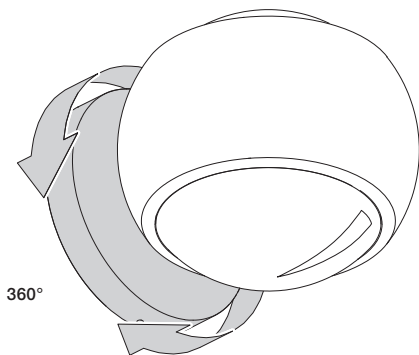

Zum Ausrichten der Leuchte  
am Cover drehen.



To adjust the luminaire rotate  
the cover.





Demontage  
io verticale  
pro

Remove  
io verticale  
pro

## Demontage io verticale pro Remove io verticale pro

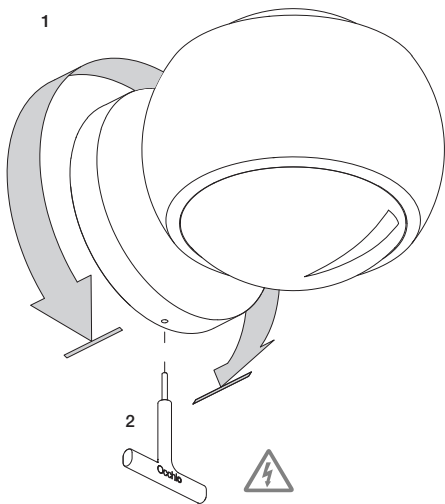

**Vor der Demontage alle stromführenden Leitungen vom Stromnetz trennen!**

**1** Leuchte bis zum Anschlag drehen. **2** Mit dem Release-Tool den Verriegelungsmechanismus nach oben drücken.



**Before dismounting, disconnect all current-carrying lines from the mains supply!**

**1** Turn the luminaire till it stop.  
**2** Push the locking mechanism by release tool upwards

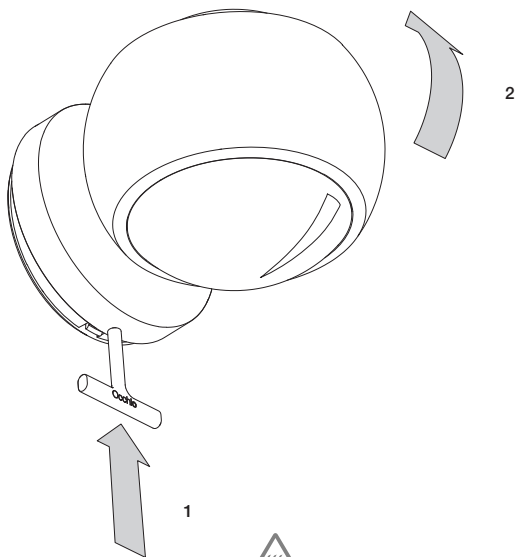

**Die Oberfläche der Leuchte kann im Dauerbetrieb heiß werden.**

- 1 Tool gedrückt halten.
- 2 Leuchte nach oben neigen.



**When used in continuous operation, the surface of the luminaire can become hot.**

- 1 Press and hold the tool.
- 2 Tilt the luminaire upwards.



Steuerung mit  
der Occhio air  
App (optional)

Control using  
the Occhio air  
app (optional)

# Steuerung mit der Occhio air App (optional) Control using the Occhio air app (optional)

## Quick guide

Die Occhio air Produkte lassen sich mit der Occhio air App einrichten und steuern.

App installieren, App öffnen und angeschlossene Leuchten einrichten.

Occhio air products can be set up and controlled using the Occhio air app.

Install App, open App and set up connected luminaires.



## Occhio air tutorials

[www.occhio.de/air-tutorials](http://www.occhio.de/air-tutorials)

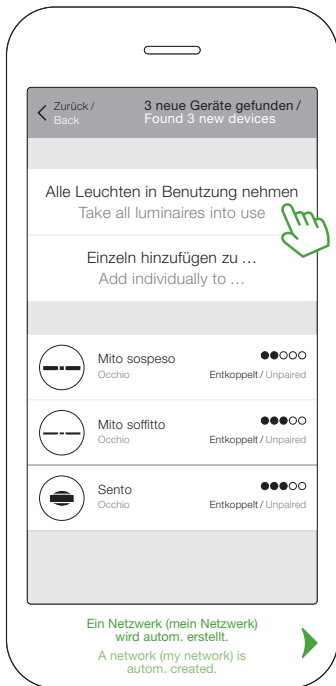

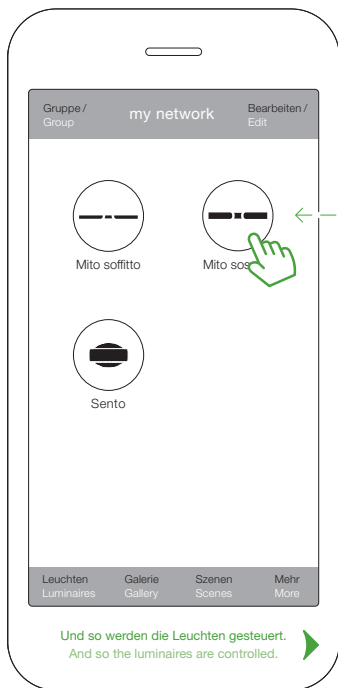

## Steuerungsgesten Control gestures

on / off  
on / off



antippen  
tap

dimmen  
dim



wischen  
swipe

up / down  
faden \*



wischen  
swipe

color tune \*\*



halten  
hold



wischen  
swipe

\* Leuchten mit beidseitigem Lichtaustritt /  
luminaires with light emission on both sides

\*\* Mito

## Steuerung mit der Occhio air App (optional) Control using the Occhio air app (optional)

### Nutzung auf mehreren Geräten

#### Use on several devices

Optional können Sie nun ihr  
erstelltes Netzwerk (mein  
Netzwerk) mit Anderen teilen.

Optionally, you can now share  
your created network (my  
network) with others.

1. Netzwerknamen  
vergeben

1. Assign name

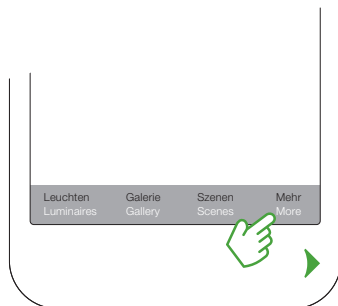

### Occhio air tutorials

[www.occhio.de/air-tutorials](http://www.occhio.de/air-tutorials)



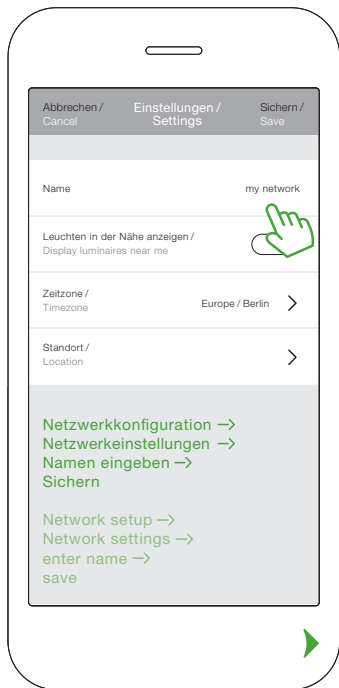

# Steuerung mit der Occhio air App (optional) Control using the Occhio air app (optional)

Netzwerk freigeben  
und schützen

Share and protect the  
network

Occhio air tutorials

[www.occhio.de/air-tutorials](http://www.occhio.de/air-tutorials)

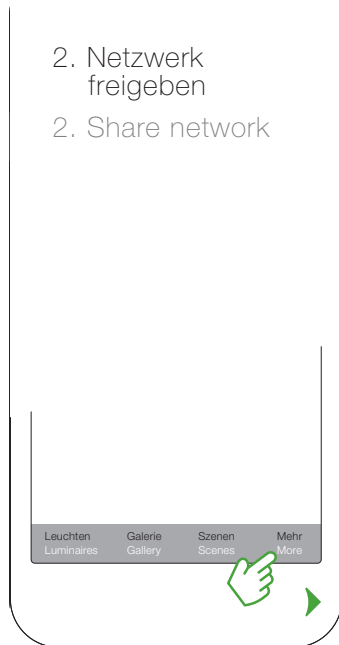

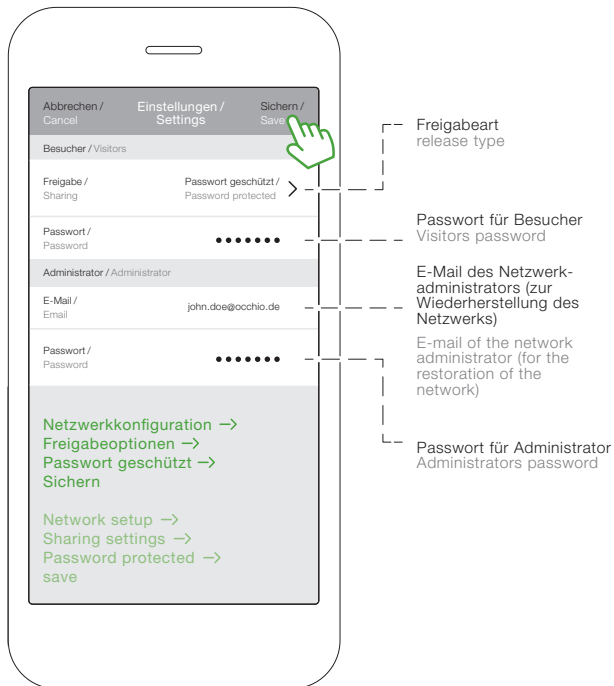



Steuerung mit  
dem Occhio air  
controller  
(optional)

Control using  
the Occhio air  
controller  
(optional)

## Steuerung mit dem Occhio air controller (optional)

### Control using the Occhio air controller (optional)

#### Occhio air controller

Intuitiv bedienbare Fernbedienung mit vier programmierbaren Tasten (Einrichtung via Occhio air App). Unabhängig von der App können einzelne Leuchten, Gruppen und Szenen gesteuert werden. Optional mit Wandhalterung erhältlich.

Maximaler Bedienkomfort und umfassende Steuerung via Bluetooth 4.0 (Bluetooth Low Energy). Schalten, dimmen, faden, color tune von einzelnen Leuchten, Gruppen und Szenen.

#### Occhio air controller

Intuitive remote control with four programmable buttons (setup via Occhio air app). Individual luminaires, groups and scenes can be controlled regardless of the app. Available with optional wall mount.

Maximum ease of use and total control via Bluetooth 4.0 (Bluetooth low energy). Switching, dimming, fading, color tune of individual luminaires, groups and scenes.



Zum Einrichten des Occhio air controllers wird die Occhio air App benötigt. Eine Video-Kurzanleitung kann unter: [www.occhio.de/air-tutorials](http://www.occhio.de/air-tutorials) aufgerufen werden.

To set up the Occhio air controller, the Occhio air app is required. A video quick start guide can be called up at [www.occhio.de/air-tutorials](http://www.occhio.de/air-tutorials).

### schalten/switch



⏏ - ☰ einzelne Leuchten, Gruppen, oder Szenen schalten

⏏ - ☰ switch individual luminaires, groups or scenes

### dimmen/dim



⊕ - ☰ einzelne Leuchten, Gruppen, oder Szenen dimmen

⊕ - ☰ dims individual luminaires, groups or scenes

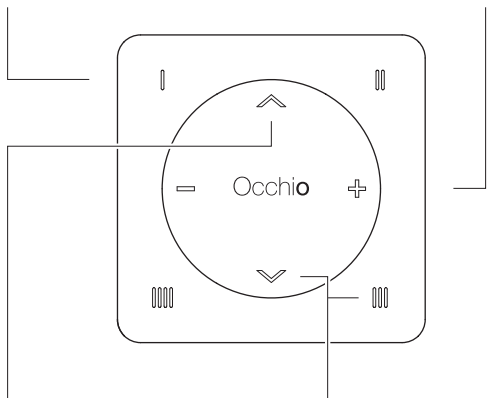

### faden\*



^ v einzelne Leuchten, Gruppen oder Szenen faden (up/down Verhältnis ändern)

^ v fades individual luminaires, groups or scenes (change up/down relation)

### color tune\*\*

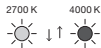

⏏ - ☰ and ^ v Farbtemperatur einzelner Leuchten, Gruppen oder Szenen einstellen

⏏ - ☰ and ^ v adjust color temperature of individual luminaires, groups or scenes

\* Mito sospeso, Sento sospeso, Sento head (beidseitig/double sided) \*\* Mito





Anhang

Appendix

## Pflegehinweise

### Care instructions

Leuchte nur in abgekühltem Zustand reinigen! Zur Reinigung der Leuchte ein trockenes Mikrofasertuch verwenden. Detaillierte Pflegehinweise sind unter [www.occhio.de/de/company/faq](http://www.occhio.de/de/company/faq) zu finden.

Always allow the luminaire to cool down before cleaning! To clean the luminaire, use a dry microfibre cloth. Detailed care instructions are available at [www.occhio.de/en/company/faq](http://www.occhio.de/en/company/faq).

## Info & Kontakt

### Information & contact

Weitere Fragen beantwortet gerne  
Ihr Occhio Fachhändler

Your Occhio specialist retailer will  
gladly answer any other questions

**[www.occhio.de](http://www.occhio.de)**  
**[info@occhio.de](mailto:info@occhio.de)**

# Technische Daten

## Technische Daten Leuchte

Artikelbezeichnung	Occhio io verticale pro
Abmessungen	L 116 × B 100 × H 94 mm
Schutzklasse	3
Anschluss	max. 500 (350 mA chrom glanz, rose gold, bronze) konst. / > 36 V DC
Dimmung	mit geeignetem Vorschaltgerät
Material Leuchte	Aluminium, verchromt, lackiert, eloxiert oder PVD-beschichtet, Kunststoff, Glas, optischer Kunststoff
LED-Leistung	18 W / 13 W (Version chrom glanz, rose gold, bronze)
Zulässige Betriebsbedingung	max. 30°C nur im Innenbereich betreiben
Prüfzeichen	IP 20     

## Technische Daten Leuchtmittel





Leuchtmittel	Occhio light module
Ausführung	LED-Modul (wechselbar)
Lebensdauer	> 50.000 Std.

## Entsorgung

Bei örtlicher Entsorgungsstelle entsorgen. Das Leuchtmittel ist recyclebar; RoHS-konform. **Nicht in den Hausmüll geben!**

# Technical data

## Technical data luminaire

Product designation	Occhio io verticale pro
Dimensions	L 116 x W 100 x H 94 mm
Safety class	3
Connection	max. 500 (350 mA shiny chrome, rose gold, bronze) const. / > 36 V DC
Dimming	with suitable power supply unit
Luminaire material	aluminium, chrome-plated, painted, anodised or PVC-coated, plastic, glass, optical plastic
LED power	18 W / 13 W (version shiny chrome, rose gold, bronze)
Permitted operating conditions	max. 30°C for indoor use only
Test symbols	IP 20     

## Technical data light source

Light source	Occhio light module
Version	LED module (replaceable)
Lifetime	> 50.000 h

## Disposal

Dispose of at the local waste disposal site. The light source is recyclable and RoHS-compliant. **Do not dispose of with household waste.**





# Occhio

[www.occhio.com](http://www.occhio.com)



010040429569667910