

Occhio

Più piano v edge pro

Più piano v pro

Montageanleitung
Mounting instructions

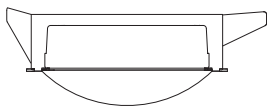

Inhalt / Contents

Sicherheitshinweise	04	Safety precautions	05
Produktbeschreibung	06	Product description	07
Schritt 1		Step 1	
Montage Optik	09	Mounting optics	09
Schritt 2		Step 2	
Montage		Mounting	
Più piano v edge pro	17	Più piano v edge pro	17
Strahler entnehmen	27	Remove spotlight	27
Montage		Mounting	
Più piano v pro	31	Più piano v pro	31
Strahler entnehmen	43	Remove spotlight	43
Anhang	47	Appendix	47
Pflegehinweise	48	Care instructions	48
Info & Kontakt	49	Information & contact	49
Technische Daten	50	Technical data	51

Sicherheitshinweise

Lesen Sie die Montage-/Gebrauchsanweisung sorgfältig durch, bevor Sie die Leuchte installieren. Beachten Sie die Sicherheitshinweise in dieser Anleitung genau und bewahren Sie die Anleitung auf.



Dieses Zeichen macht Sie auf eine gefährliche Situation aufmerksam, die eine schwere Verletzung oder den Tod nach sich ziehen kann, wenn sie nicht beachtet wird. Es macht Sie zudem auf mögliche Sachschäden und andere wichtige Informationen in Verbindung mit diesem Produkt aufmerksam.



Die Montage von Elektrokomponenten darf nur von qualifiziertem Fachpersonal durchgeführt werden. Reparaturarbeiten dürfen nur von autorisiertem Fachpersonal oder dem Hersteller durchgeführt werden. Vor allen Arbeiten an der Leuchte (Installation, Reinigung etc.) diese unbedingt vom Stromnetz trennen.



Dieses Zeichen macht Sie auf Situationen aufmerksam, bei denen Sie direkt in das Licht der LED blicken könnten. Dies kann zu Nachbildern und bei längerer Dauer zu Schädigungen der Augen führen.



Sicherheitsabstand zu brennbaren Objekten einhalten: 20 cm!



Dieses Zeichen macht Sie auf heiße Oberflächen aufmerksam, deren Berührung Verbrennungen zur Folge haben können.

Achtung: Die Oberfläche der Leuchte kann nach längerer Betriebsdauer heiß sein! Vor allen Arbeiten an der Leuchte (Montage usw.), Leuchte immer ausschalten und mindestens 30 Minuten abkühlen lassen.

Safety precautions

Read through the mounting/ use instructions carefully before installing the luminaire. Follow the safety precautions in these instructions closely and keep the instructions in a safe place.



This symbol warns you of a dangerous situation which could lead to serious injury or even death if the instructions are not observed. It also draws your attention to possible material damage and provides other important information in connection with this product.



The assembly and installation of electrical components must be carried out only by qualified personnel. Repairs must be carried out only by authorised, qualified personnel or the manufacturer. Before performing any work on the luminaire (installation, cleaning, etc.), it must be disconnected from the mains supply.



This symbol draws your attention to situations in which you could look directly into the light of the LED. This may cause an after-image effect and may result in damage to the eyes if you look at the light directly for prolonged periods.



Maintain the minimum safety distance from flammable materials: 20 cm.



This symbol warns you of hot surfaces, which could cause burns if touched.

Caution: When used for prolonged periods, the surface of the luminaire can become hot. Before performing any work on the luminaire (fitting the luminaire etc.), always switch the luminaire off and let it cool for at least 30 minutes.

Produktbeschreibung

LED Einbaustrahler (downlight nicht schwenkbar) mit magnetisch fixierbaren covers (round & square) oder mit filigranem Deckenrand (Più piano v edge pro) für deckenbündigen Einbau in Hohldecken oder feste Decken mit Deckendose. Die Montage erfolgt durch einen einfachen Spannflügel-Mechanismus der ohne Verschraubungen auskommt.

Wahlweise mit Linsenoptik (Più) oder flachem cone Glas mit innenliegender Linse (Più R). Version mit externem Vorschaltgerät, Anschluss an Stromquelle (Treiber). Dimmbar bauseits über dimmbares Vorschaltgerät. Lichtwirkung durch optionale inserts jederzeit über einen einfachen Mechanismus veränderbar, dichroitische Farbfilter zusätzlich einsetzbar, Occhio light module wechselbar.

Product description

LED recessed spotlight (down-light non-tiltable) with magnetically attached covers (round & square) or with filigree ceiling Più piano v edge pro for flush mounting in hollow ceilings or solid ceilings with ceiling box. The spotlight is mounted with a simple tension wing mechanism and requires no screw fittings.

Choice of lens design (Più) or flat cone glass with interior lens (Più R). Version with external power supply unit, connection to power source (driver). Can be dimmed at the installation location with a dimmable power supply unit. Optional inserts allow the lighting effect to be changed at any time with a simple mechanism; dichroic color filters can also be used, Occhio light modules can be exchanged.

Montage
Optik

Mounting
optics

Montage Optik / Mounting optics

Più piano Überblick Optiken / Più piano overview optics

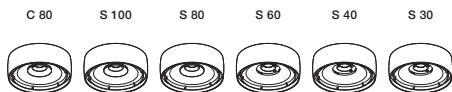

kleine Linse
flach / small
lens low



kleine Linse
medium / small
lens medium



kleine Linse
hoch / small
lens high

satiniertes
Glas / satinised
glass



soft edge Glas /
soft edge glass



Fresnel Linse /
fresnel lens



Farbfilter
(optional) / color
filter (optional)



Linse / lens



80°,
contour

100°, soft

80°, soft

60°, soft

40°, soft

30°, soft



Più R piano Übersicht Optiken / Più R piano overview optics

	B	C 100	C 80	S 100	S 80	S 60	S 40	S 30
kleine Linse flach / small lens low								
kleine Linse medium / small lens medium								
kleine Linse hoch / small lens high								
satiniertes Glas / satinised glass								
soft edge Glas/ soft edge glass								
Fresnel Linse / fresnel lens								
Farbfilter (optional) / color filter (optional)								
cone Glas/ cone glass								
diffus	100°, contour	80°, contour	100°, soft	80°, soft	60°, soft	40°, soft	30°, soft	30°, soft

Montage Optik / Mounting optics

Cone Ring einsetzen

(Entnehmen in umgekehrter Reihenfolge)

Insert cone ring

(remove in reverse order)

Nur notwendig wenn **keine** kleine Linse verwendet wird

Only necessary if **no** small lens is used

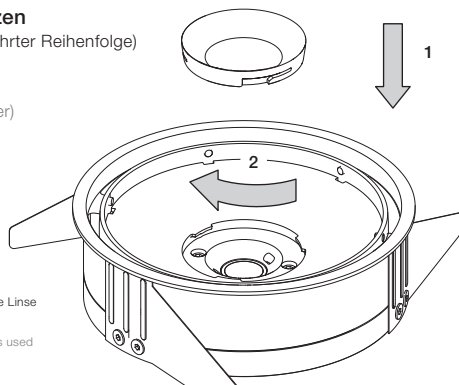

Kleine Linse einsetzen

(Entnehmen in umgekehrter Reihenfolge)

Insert small lens

(remove in reverse order)

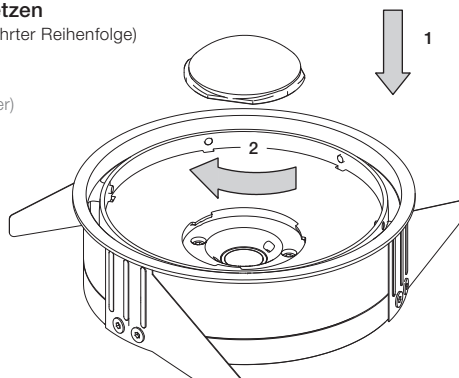



Inserts einsetzen (Entnehmen in umgekehrter Reihenfolge)

Insert inserts (remove in reverse order)

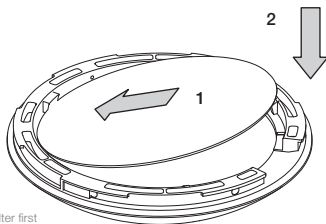
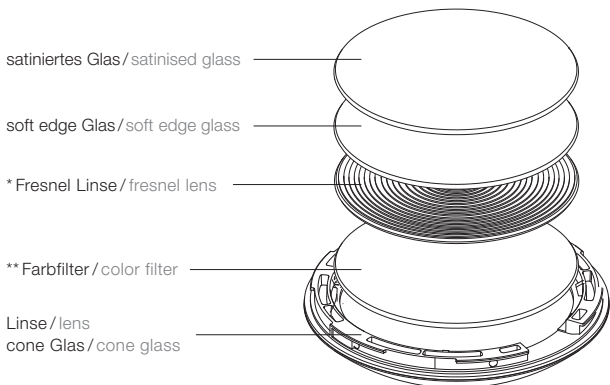

* Siehe nächste Seite / see next page

** Farbfilter immer zuerst einlegen / Always insert color filter first

Montage Optik / Mounting optics

Fresnel Linse → Linse

Oberfläche mit Struktur zeigt nach oben!



fresnel lens → lens

Surface with structure points upwards!



Fresnel Linse /
fresnel lens



Linse / lens

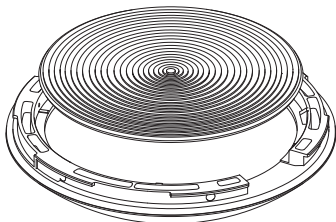

Fresnel Linse → cone Glas

Oberfläche mit Struktur zeigt nach unten!



fresnel lens → cone glass

Surface with structure points downwards!



Fresnel Linse /
fresnel lens



cone Glas /
cone glass

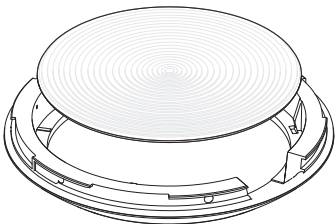



Linse oder cone Glas einsetzen

(Entnehmen in umgekehrter Reihenfolge)

Insert lens or cone glass

(remove in reverse order)

Linse/lens

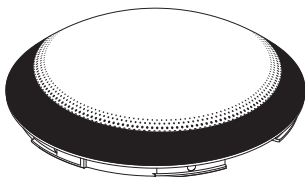

cone Glas/cone glass

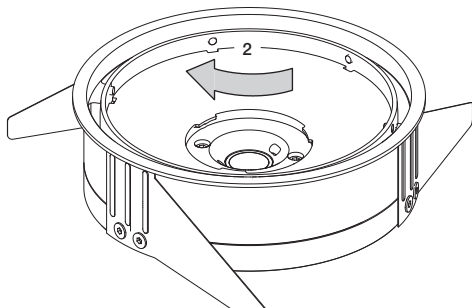
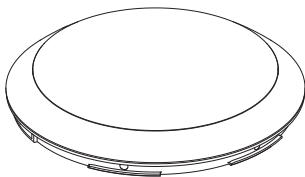

Montage

Più piano v edge pro

Mounting

Più piano v edge pro

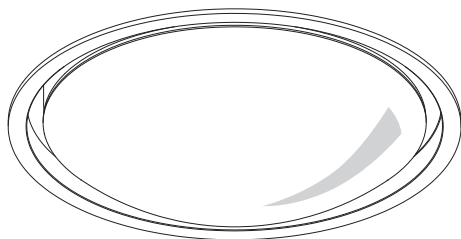



Leuchtenkabel mit Stecker /
luminaire cable with plug

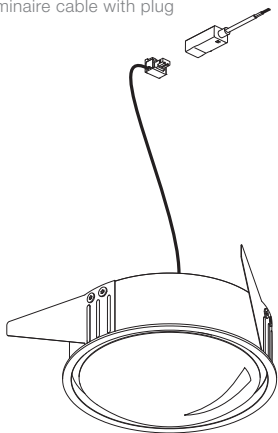

Piu piano v edge pro

externes Vorschaltgerät*
external power supply unit*

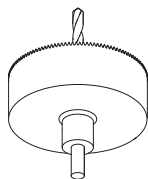
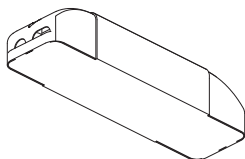

Lochsäge (optional) /
hole saw (optional)



release tool

* max. 700 mA konst. / >36 V DC
(nicht im Lieferumfang enthalten / not in scope of delivery)

Ausschnitt herstellen (ø 125 mm)
create cutout (ø 125 mm)



Achtung
Vor der Montage
alle stromführenden
Leitungen vom
Stromnetz trennen



Caution
Before fitting, discon-
nect all currentcarrying
lines from the mains
supply

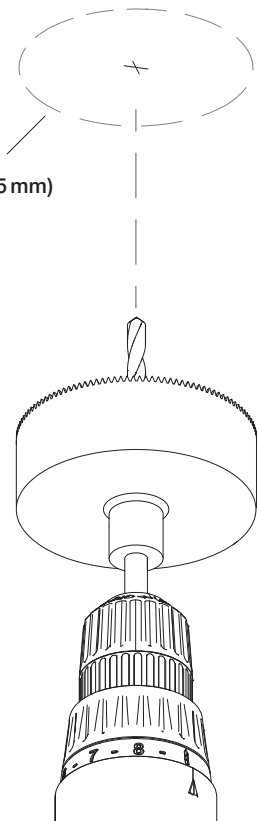

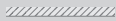

Deckenstärke /
ceiling thickness
10–25 mm

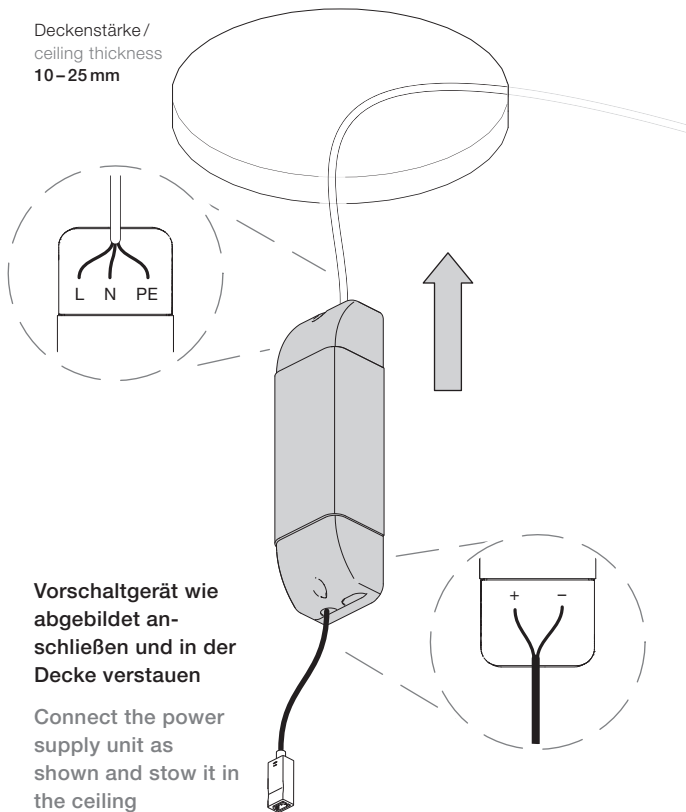

**Vorschaltgerät wie
abgebildet an-
schließen und in der
Decke verstauen**

**Connect the power
supply unit as
shown and stow it in
the ceiling**

Steckverbindung herstellen
establish plug connection

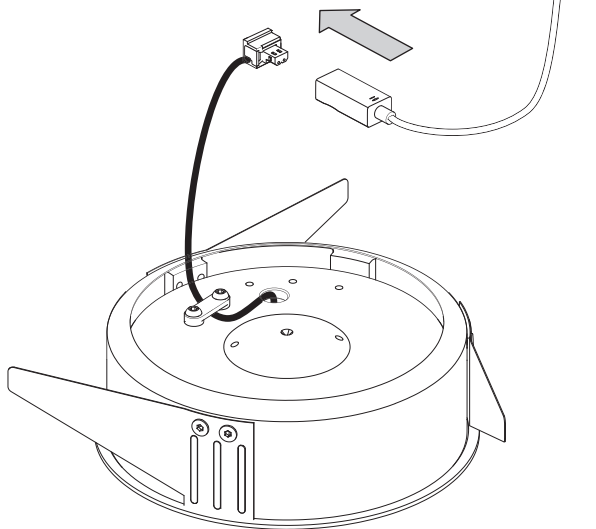



**Spannflügel anlegen und
tube im Uhrzeigersinn
eindreihen**

**apply tension wings and turn
tube in clockwise**

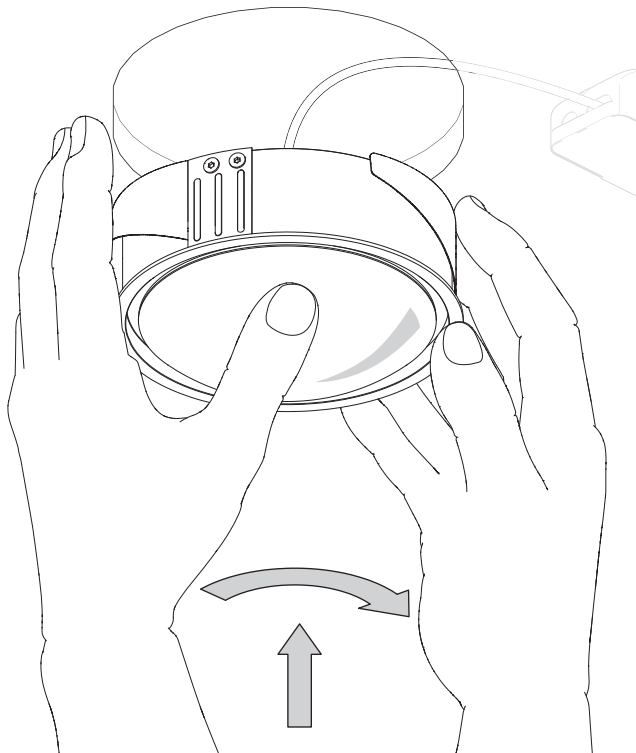

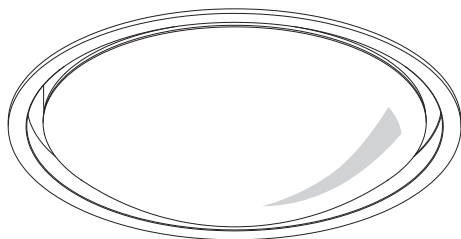

**Die Leuchte ist nun fertig
montiert**

**The luminaire is now
completely assembled**

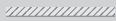

Strahler
entnehmen

Remove
spotlight

Strahler entnehmen / Remove spotlight

Zu **Wartungszwecken**
das release tool ver-
wenden

For **maintenance**
purposes use the
release tool



Achtung
Die Oberfläche des
Strahlers kann im
Dauerbetrieb heiß
werden



Caution
When used in
continuous opera-
tion, the surface of
the spotlight can
become hot

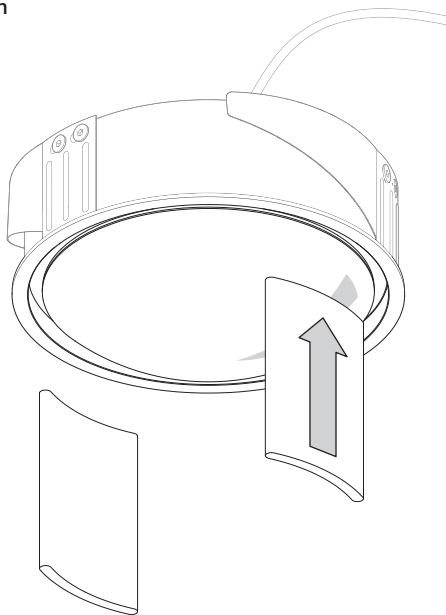

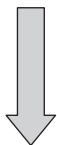
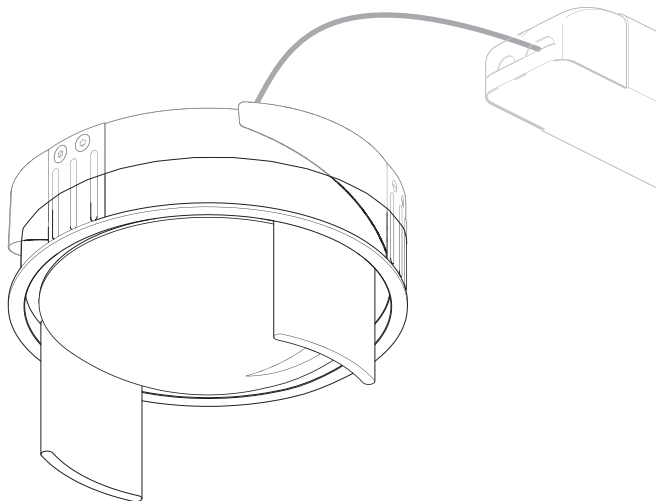
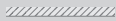

Die Leuchte im Uhrzeiger-
sinn drehen und nach unten
entnehmen

Turn the luminaire clockwise
and remove it downwards

Montage

Più piano v pro

Mounting

Più piano v pro

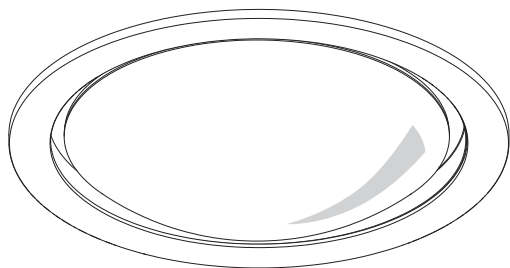

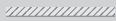

Magnethaltering /
magnetic retaining ring

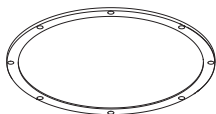

externes Vorschaltgerät*
external power supply unit*

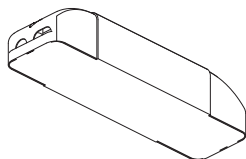

Leuchtenkabel mit Stecker /
luminaire cable with plug

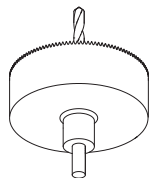
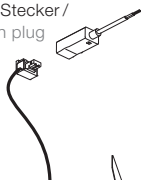

Lochsäge (optional) /
hole saw (optional)

Piu piano v pro

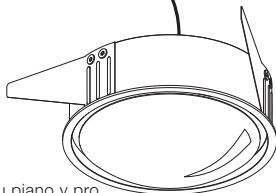

cover

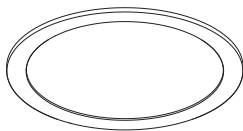

release tool

* max. 700 mA konst. / >36 V DC
(nicht im Lieferumfang enthalten / not in scope of delivery)

Ausschnitt herstellen ($\varnothing 125\text{ mm}$)
create cutout ($\varnothing 125\text{ mm}$)



Achtung
Vor der Montage
alle stromföhren-
den Leitungen vom
Stromnetz trennen



Caution
Before fitting, discon-
nect all currentcarrying
lines from the mains
supply

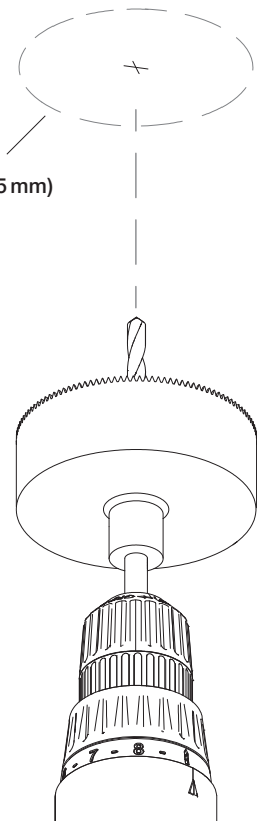



Deckenstärke /
ceiling thickness
10–25 mm

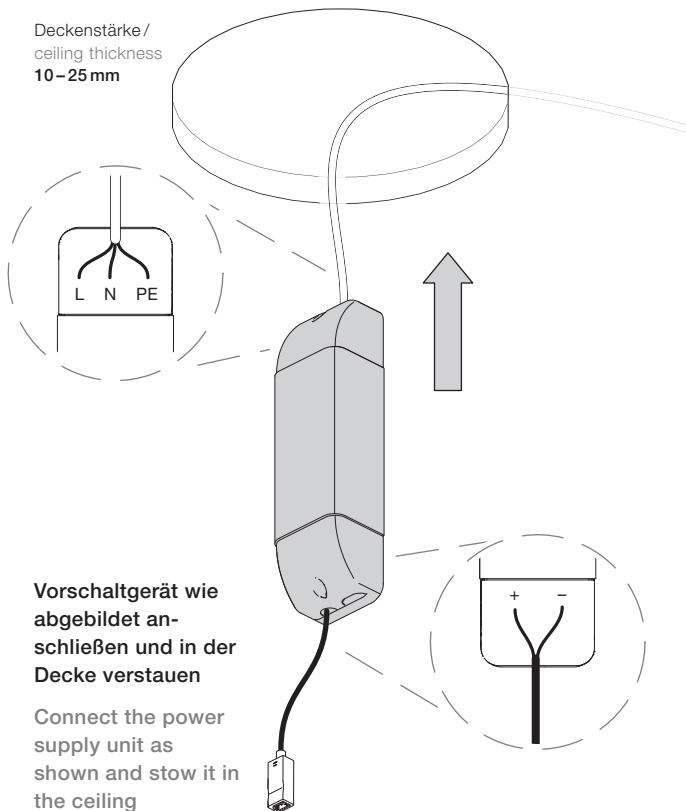

**Vorschaltgerät wie
abgebildet an-
schließen und in der
Decke verstauen**

**Connect the power
supply unit as
shown and stow it in
the ceiling**



**Spannflügel anlegen und
Magnethaltering aufsetzen**

apply the tension wings and
put on magnetic retaining ring



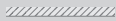

Steckverbindung herstellen
establish plug connection

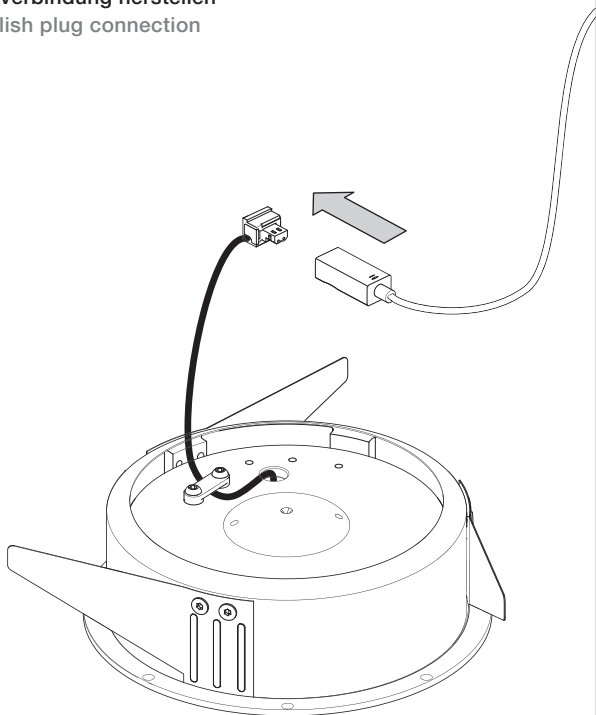

Montage / Mounting

**Spannflügel anlegen und
tube im Uhrzeigersinn
eindreihen**

**apply tension wings and turn
tube in clockwise**

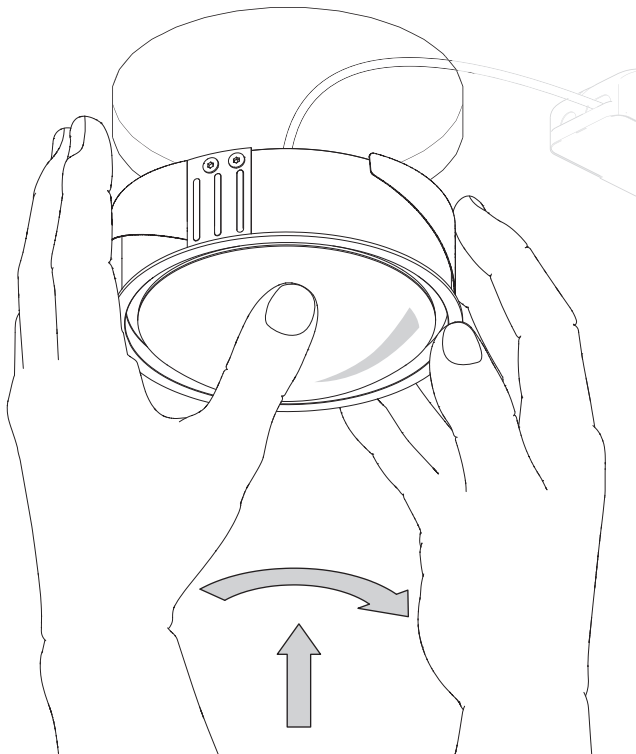

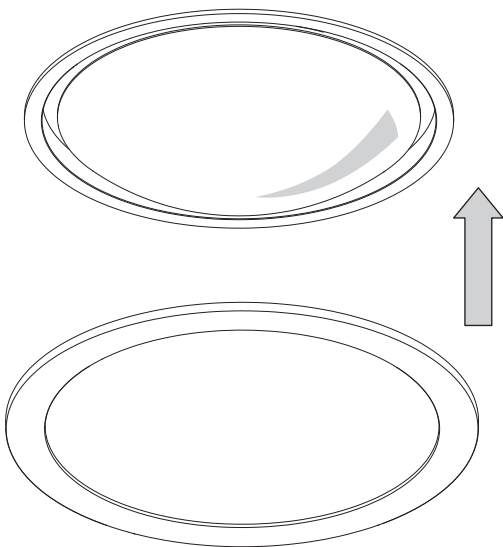

**cover auf den Magnethal-
ring platzieren**

**place the cover on the
magnetic retaining ring**

Montage / Mounting

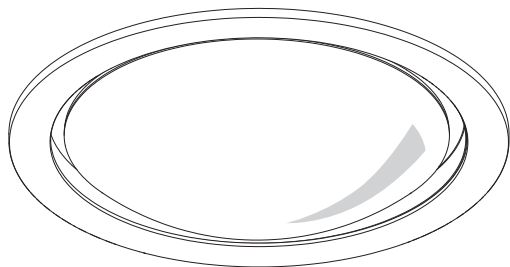

**Die Leuchte ist nun fertig
montiert**

**The luminaire is now
completely assembled**

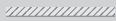

Strahler
entnehmen

Remove
spotlight

Strahler entnehmen / Remove spotlight

Zu **Wartungszwecken**
cover entfernen, das
release tool verwenden

For **maintenance**
purposes remove co-
ver, use the release tool



Achtung
Die Oberfläche des
Strahlers kann im
Dauerbetrieb heiß
werden



Caution
When used in
continuous opera-
tion, the surface of
the spotlight can
become hot

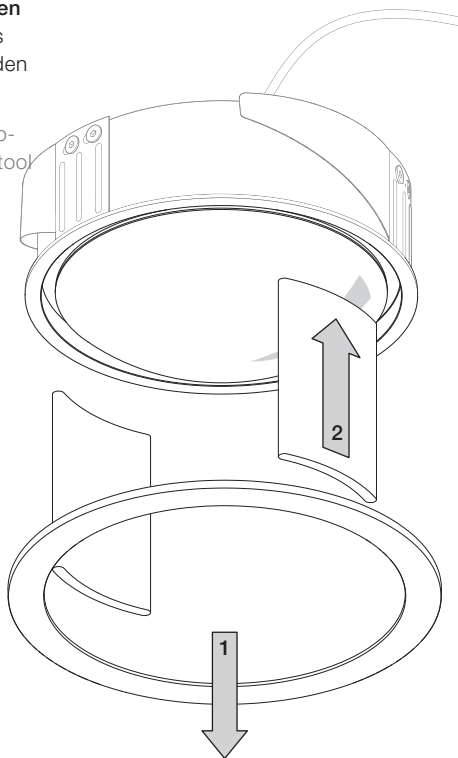

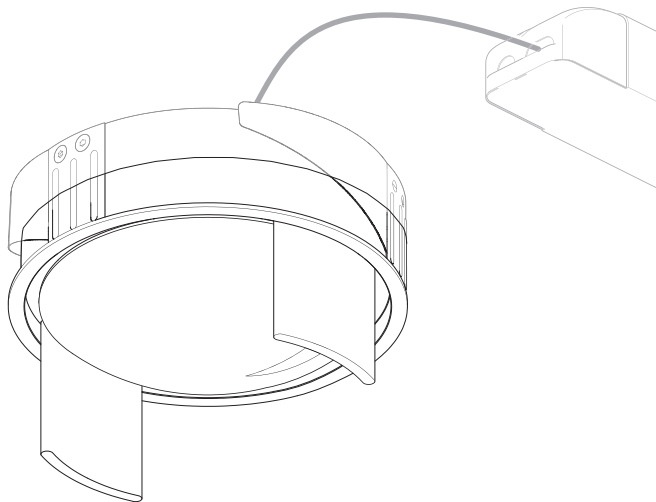
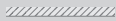

Die Leuchte im Uhrzeiger-
sinn drehen und nach unten
entnehmen

Turn the luminaire clockwise
and remove it downwards

Anhang

Appendix

Pflegehinweise

Care instructions

Leuchte nur in abgekühltem Zustand reinigen! Zur Reinigung der Leuchte ein trockenes Mikrofaser-tuch verwenden. Detaillierte Pflegehinweise sind unter www.occhio.com/de/company/faq zu finden.

Always allow the luminaire to cool down before cleaning! To clean the luminaire, use a dry microfibre cloth. Detailed care instructions are available at www.occhio.com/en/company/faq.

Info & Kontakt

Information & contact

Weitere Fragen beantwortet gerne
Ihr Occhio Fachhändler

Your Occhio specialist retailer will
gladly answer any other questions

www.occhio.com
info@occhio.com

Technische Daten

Technische Daten

Artikelbezeichnung	Più piano v pro, Più piano v edge pro
Abmessungen	Più piano v pro head ø 125 mm, H 38 mm tube ø 128 mm, Einbautiefe 62 mm
	Più piano v edge pro head ø 125 mm, H 38 mm tube ø 128 mm, Einbautiefe 62 mm
Schutzklasse	3
Vorschaltgerät	extern
Anschluss	max. 700 mA konst. / > 36 V DC
Dimmung	mit geeignetem Vorschaltgerät
Material	Aluminium, Messing, Stahl verchromt oder lackiert, optischer Kunststoff, Glas
LED-Leistung	26 W
Zulässige Betriebsbedingung	max. 30°C nur im Innenbereich betreiben
Prüfzeichen	IP 20        

Technische Daten Leuchtmittel









Leuchtmittel	Occhio light module
Ausführung	LED-Modul (wechselbar)
Lebensdauer	> 50.000 Std.

Entsorgung

Bei örtlicher Entsorgungsstelle entsorgen. Più piano v pro, Più piano v edge pro sind recyclebar; RoHS-konform. **Nicht in den Hausmüll geben!**

Technical data

Technical data

Product designation	Più piano v pro, Più piano v edge pro
Dimensions	Più piano v pro head ø 125 mm, H 38 mm tube ø 128 mm, installation depth 62 mm Più piano v edge pro head ø 125 mm, H 38 mm tube ø 128 mm, installation depth 62 mm
Safety class	3
Power supply unit	external
Connection	max. 700 mA const. / > 36 V DC
Dimming	with suitable power supply unit
Material	aluminium, brass, steel – chrome-plated or painted, optical plastic, glass
LED-power	26 W
Permitted operating conditions	max. 30°C for indoor use only
Test symbols	IP 20        

Technical data light source

Light source	Occhio light module
Version	LED module (replaceable)
Lifetime	> 50.000 hrs.

Disposal

Dispose of at a local disposal site. Più piano v pro, Più piano v edge pro are recyclable and RoHS compliant. **Do not dispose of with the household waste!**

Occhio

www.occhio.com



010405944519029210