

## Più piano in VOLT datasheet

LED recessed spotlight for hollow ceilings or solid ceilings with ceiling box. Mounting flush with ceiling (Più piano) and recessed installation (Più piano in) are both possible. Optionally available with lens optics (Più) or flat cone glass with internal lens (Più R). Version for connection to 230V AC/50 Hz mains voltage. Dimmable via trailing-edge phase-cut dimmer\*. Head can be aligned in any direction thanks to the ball joint principle (Più piano: 30°, Più piano in: 20°). Choice of several variants for different installation solutions. Covers that are held in place magnetically are used in ceiling-mounted versions and in frameless models which either have a mounting plate or are mounted on panels that are accessible from the rear (used in hollow ceilings). Using a simple mechanism, the lighting effect can be changed at any time through the use of optional inserts, dichroitic colour filter can be additionally inserted, VOLT light engine replaceable.

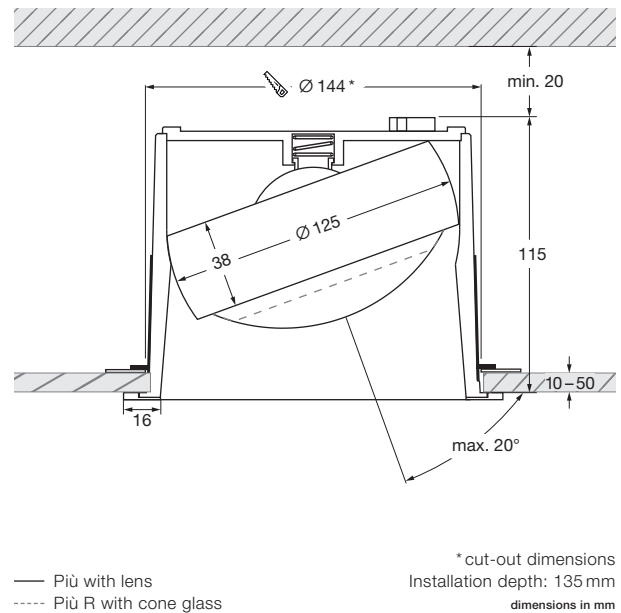

### technical data Più piano in VOLT

properties	material	aluminium, brass, steel – chrome-plated or painted, optical plastic, glass
	turning range body	360°
	movability head	20° (with stop)
	weight	1.4 kg
surface	head / cover	matt gold, rose gold, bronze, shiny chrome, matt chrome, glossy white, matt white, matt black, phantom, black phantom
	tube	matt white, matt black
	lens	matt white, matt black (lens edge)
	cone glass	rose gold, bronze, shiny chrome, matt chrome, matt white, matt black, phantom, black phantom
VOLT light engine	average life time	> 40.000 hrs
	energy efficiency class (luminous efficiency)	G (58 lm / W)
	power	LED 26 W (switchable 26 W / 18 W / 13 W)
	color rendering index	perfect color; CRI Ra 97
electricity	color temperature (color consistency)	2700 K, 3000 K (2-step)
	dimming	by trailing-edge phase-cut dimmer*
	connection	operation at 230 V AC / 50 Hz
	power factor power supply (cos φ1)	0.9
flicker / stroboscopic effect	1 (PstLM) / 0.9 (SVM)	
permitted operating conditions	max. 30°C for indoor use only	

\* For a list of compatible dimmers, see [www.occhio.com/dim\\_en](http://www.occhio.com/dim_en)

## Più piano in VOLT

20° swivel angle  
360° rotatability

**Più piano in VOLT**  
head H 38 mm, ø 125 mm

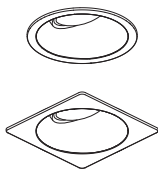

### mounting tube with cover

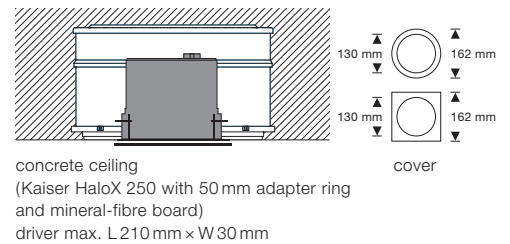
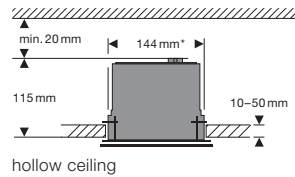

**Più piano in VOLT pure**  
head H 38 mm, ø 125 mm



### holding ring for panel for seamless mounting

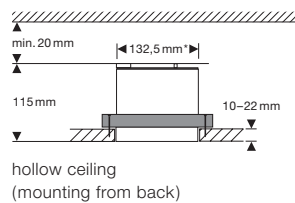

### flush-mount ring for seamless mounting

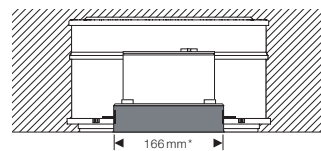

concrete ceiling plastered, no fair-faced concrete  
(Kaiser HaloX 250 with 50 mm adapter ring and mineral-fibre board) driver max. L 210 mm x W 30 mm

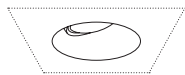
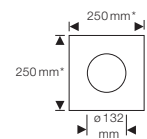

### mounting board for seamless mounting

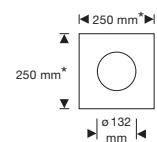
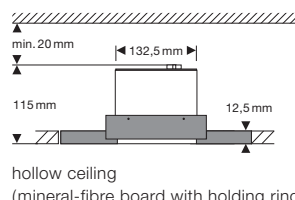

\*cut-out dimensions

## Più piano in VOLT

through-wiring

### Più piano in VOLT

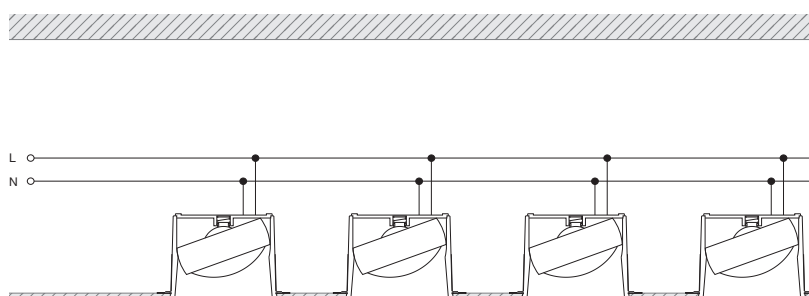

### Più piano in VOLT +Occhio air module max. 5 luminaires

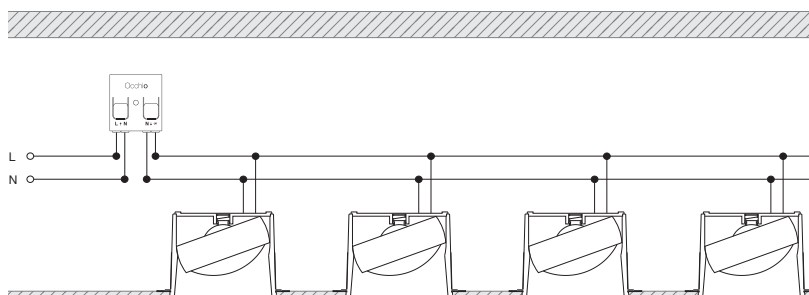

### Più piano in VOLT + trailing-edge phase-cut dimmer max. number depends on the max. wattage of trailing-edge phase-cut dimmer

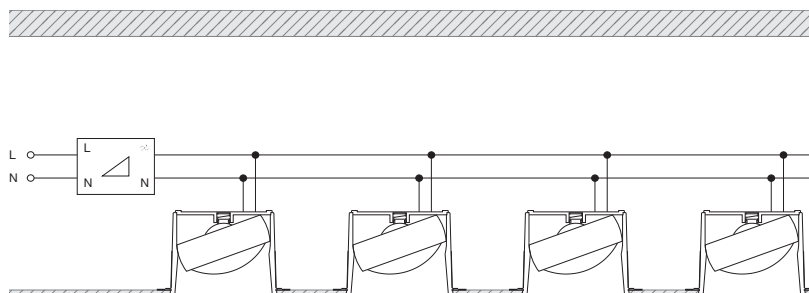

## Più piano in VOLT overview optics

Più	C 80	S 100	S 80	S 60	S 40	S 30		
small lens low								
small lens medium								
satinised glass								
soft edge glass								
fresnel lens								
color filter (optional)								
lens								
Più R	B	C 100	C 80	S 100	S 80	S 60	S 40	S 30
small lens low								
small lens medium								
small lens high								
satinised glass								
soft edge glass								
fresnel lens								
color filter (optional)								
cone glass								
	diffus	100°, contour	80°, contour	100°, soft	80°, soft	60°, soft	40°, soft	30°, soft

Più piano in VOLT  
Più lighting effects

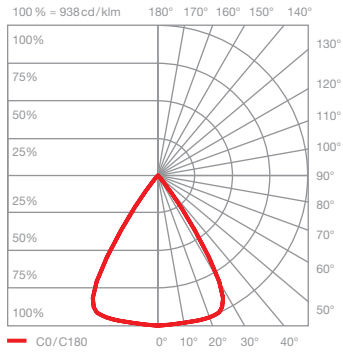
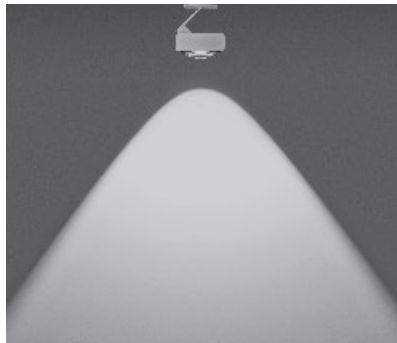

**C 80 contour**  
scattered light with contour beam angle  
(approx. 80°)

inserts: lens

luminous flux:	perfect color	26 W	1290 lm
	perfect color	18 W	970 lm
	perfect color	13 W	730 lm

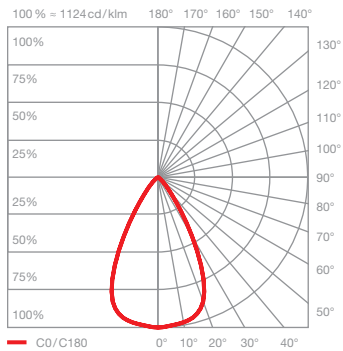
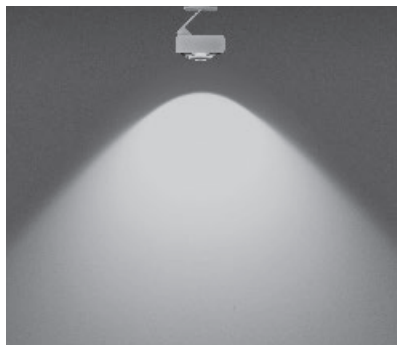

**S 100 soft**  
scattered light with soft contour beam angle  
(approx. 100°)

inserts: lens  
satinised glass

luminous flux:	perfect color	26 W	1030 lm
	perfect color	18 W	780 lm
	perfect color	13 W	580 lm

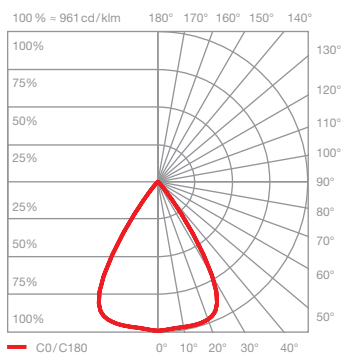
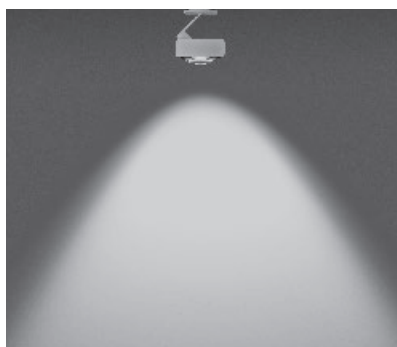

**S 80 soft**  
scattered light with soft contour beam angle  
(approx. 80°)

inserts: lens  
soft edge glass

luminous flux:	perfect color	26 W	1140 lm
	perfect color	18 W	860 lm
	perfect color	13 W	640 lm

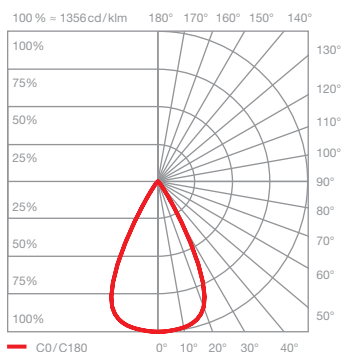
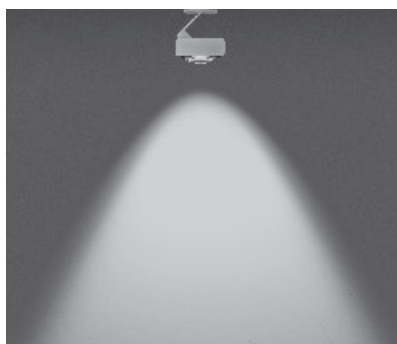

**S 60 soft**  
scattered light with soft contour beam angle  
(approx. 60°)

inserts: lens  
small lens low  
soft edge glass

luminous flux:	perfect color	26 W	1240 lm
	perfect color	18 W	930 lm
	perfect color	13 W	700 lm

Più piano in VOLT  
Più lighting effects

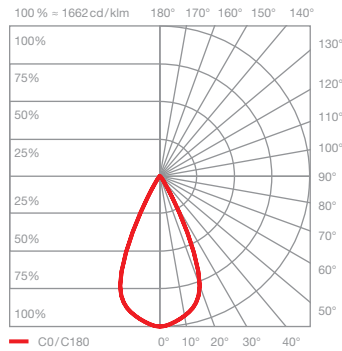

### S40 soft

scattered light with soft contour beam angle (approx. 40°)

inserts: lens  
small lens medium  
soft edge glass

luminous flux: perfect color 26W 1280lm  
perfect color 18W 960lm  
perfect color 13W 720lm

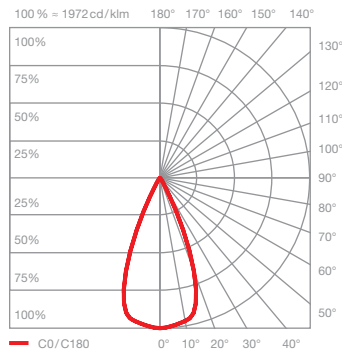

### S30 soft

scattered light with soft contour beam angle (approx. 30°)

inserts: lens  
small lens medium  
fresnel lens

luminous flux: perfect color 26W 1270lm  
perfect color 18W 950lm  
perfect color 13W 710lm

## Più piano in VOLT Più R lighting effects

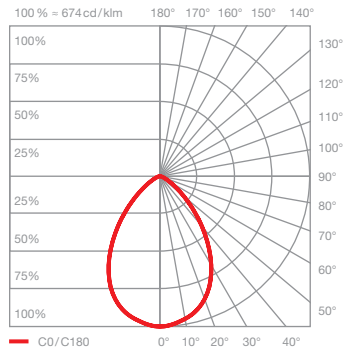

### B diffus diffused light

inserts: cone glass  
small lens low  
satinised glass

luminous flux: perfect color 26 W 1200 lm  
perfect color 18 W 900 lm  
perfect color 13 W 680 lm

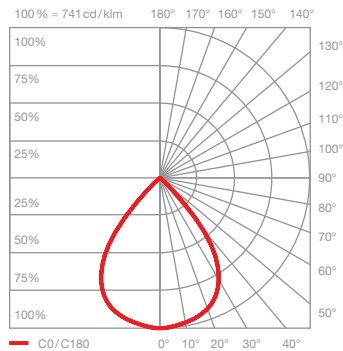
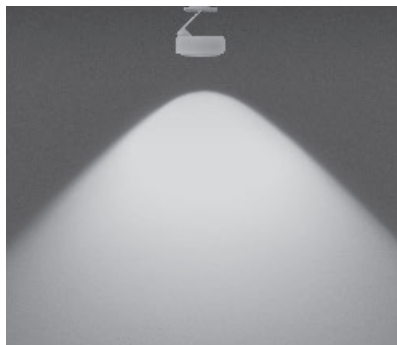

### C 100 contour scattered light with contour beam angle (approx. 100°)

inserts: cone glass  
small lens low

luminous flux: perfect color 26 W 1340 lm  
perfect color 18 W 1000 lm  
perfect color 13 W 750 lm

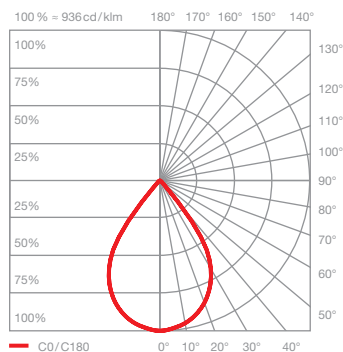
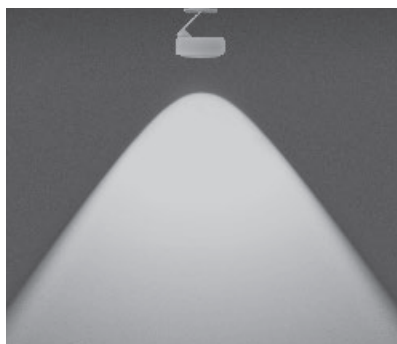

### C 80 contour scattered light with contour beam angle (approx. 80°)

inserts: cone glass  
small lens medium

luminous flux: perfect color 26 W 1400 lm  
perfect color 18 W 1050 lm  
perfect color 13 W 790 lm

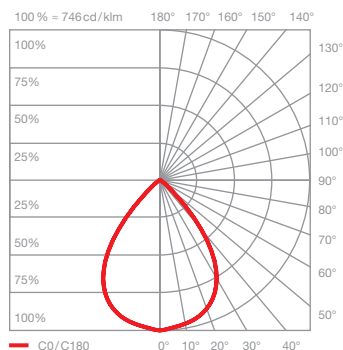
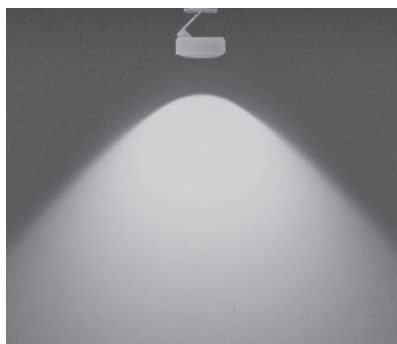

### S 100 soft scattered light with soft contour beam angle (approx. 100°)

inserts: cone glass  
small lens low  
soft edge glass

luminous flux: perfect color 26 W 1210 lm  
perfect color 18 W 910 lm  
perfect color 13 W 680 lm

## Più piano in VOLT Più R lighting effects

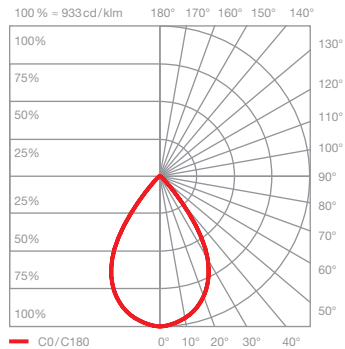
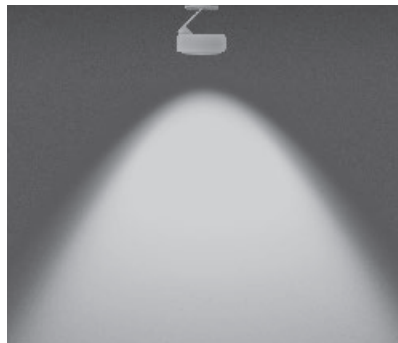

### S80 soft

scattered light with soft contour beam angle (approx. 80°)

inserts: cone glass  
small lens medium  
soft edge glass

luminous flux: perfect color 26 W 1250 lm  
perfect color 18 W 940 lm  
perfect color 13 W 710 lm

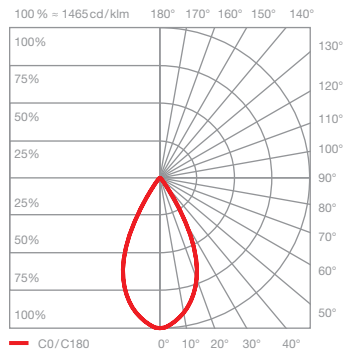
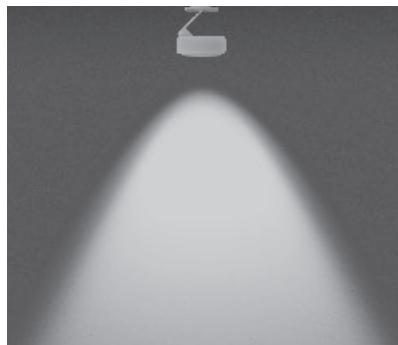

### S60 soft

scattered light with soft contour beam angle (approx. 60°)

inserts: cone glass  
small lens high  
soft edge glass

luminous flux: perfect color 26 W 1220 lm  
perfect color 18 W 920 lm  
perfect color 13 W 690 lm

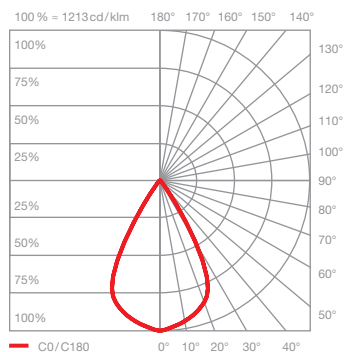
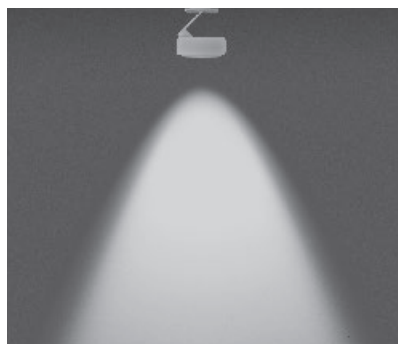

### S40 soft

scattered light with soft contour beam angle (approx. 40°)

inserts: cone glass  
small lens medium  
fresnel lens

luminous flux: perfect color 26 W 1220 lm  
perfect color 18 W 920 lm  
perfect color 13 W 690 lm

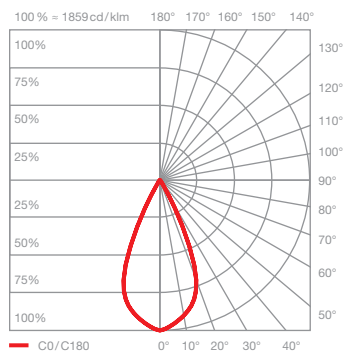

### S30 soft

scattered light with soft contour beam angle (approx. 30°)

inserts: cone glass  
small lens high  
fresnel lens

luminous flux: perfect color 26 W 1250 lm  
perfect color 18 W 940 lm  
perfect color 13 W 700 lm