

Più piano edge pro datasheet

LED recessed spotlight with filigree ceiling edge for hollow ceilings or solid ceilings with ceiling box. The spotlight is mounted with a simple tension wing mechanism that requires no screw fittings. Can be mounted flush with the ceiling (Più piano edge) or recessed (Più piano in edge).

Choice of lens design (Più) or flat cone glass with interior lens (Più R). Version with external power supply unit, connection to power source (driver). Can be dimmed at the installation location with a dimmable power supply unit. Head can be freely positioned in all directions with the unique ball joint principle (Più piano 30°, Più piano in 20°). Optional inserts allow the lighting effect to be changed at any time with a simple mechanism; dichroic color filters can also be used, Occhio light modules can be exchanged.

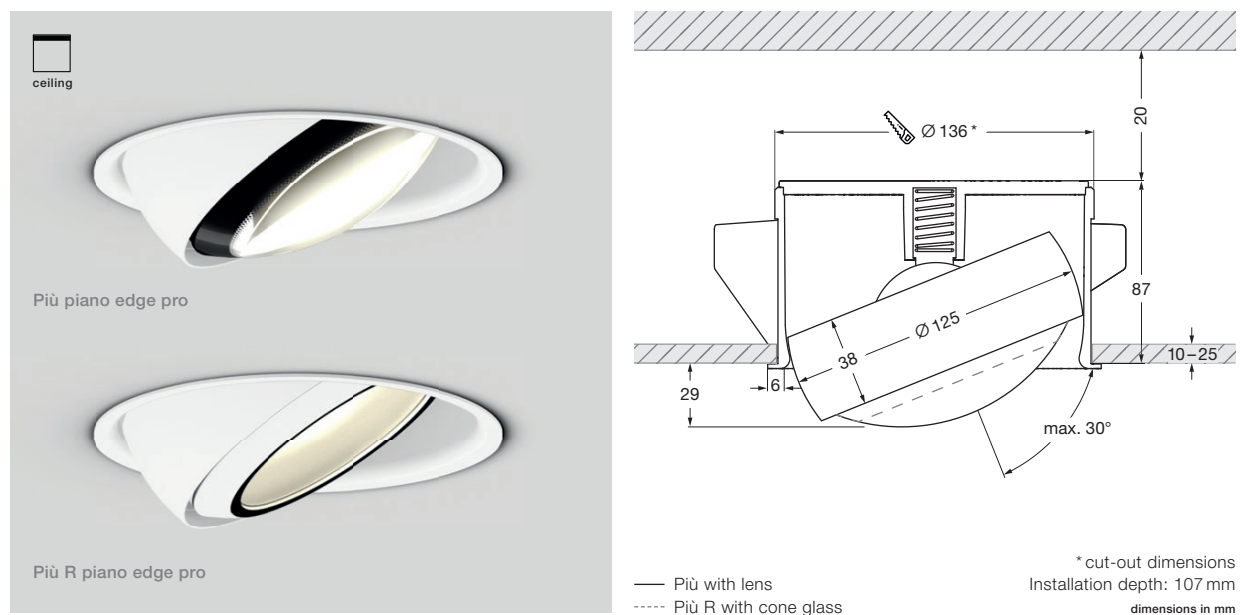

technical data Più piano edge pro

properties	material	aluminium, brass, steel – chrome-plated or painted, optical plastic, glass	
	turning range head	360°	
	mobility head	30° (with stop)	
	weight	1.2 kg	
surface	head	matt gold, rose gold, bronze, shiny chrome, matt chrome, glossy white, matt white, matt black, phantom, black phantom	
	tube	matt white, matt black	
	lens	matt white, matt black (lens edge)	
	cone glass	rose gold, bronze, shiny chrome, matt chrome, matt white, matt black, phantom, black phantom	
Occhio light module	average life time	> 50.000 hrs	
	energy efficiency class (luminous efficiency)	G (69 lm / W)	
	power	LED 26 W	
	color rendering index	perfect color; CRI Ra 97	high flux; CRI Ra 85
	color temperature	2700 K, 3000 K, 4000 K	3000 K, 3500 K, 4000 K
electricity	dimming	with suitable power supply unit	
	power supply unit	max. 700 mA const. / > 36 V DC	
	permitted operating conditions	max. 30°C for indoor use only	

* concrete ceiling (Kaiser HaloX 250 with mineral-fibre board) driver max. L 210 mm x W 90 mm

Più piano edge pro

30° swivel angle
360° rotatability

Più piano edge pro
head H 38 mm, ϕ 125 mm



edge mounting tube

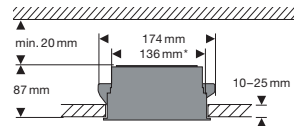

hollow ceiling

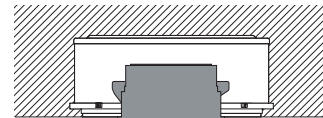

concrete ceiling
(Kaiser HaloX 250 with mineral-fibre board)
driver max. L 210 mm x W 30 mm



ceiling edge

* cut-out dimensions

Più piano edge pro overview optics

Più	C 80	S 100	S 80	S 60	S 40	S 30		
small lens low								
small lens medium								
satinised glass								
soft edge glass								
fresnel lens								
color filter (optional)								
lens								
Più R	B	C 100	C 80	S 100	S 80	S 60	S 40	S 30
small lens low								
small lens medium								
small lens high								
satinised glass								
soft edge glass								
fresnel lens								
color filter (optional)								
cone glass								
	diffus	100°, contour	80°, contour	100°, soft	80°, soft	60°, soft	40°, soft	30°, soft

Più piano edge pro
Più lighting effects

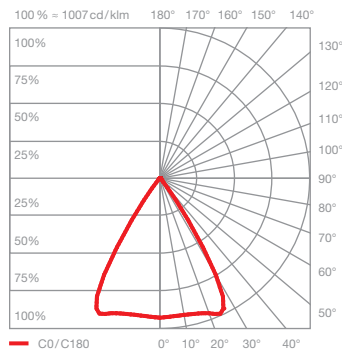
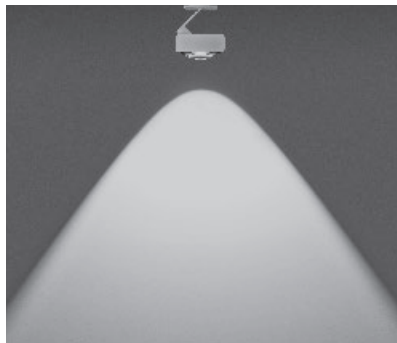

C 80 contour

scattered light with contour beam angle
(approx. 80°)

inserts: lens

luminous flux: perfect color 26 W 1640 lm
high flux 26 W 2240 lm

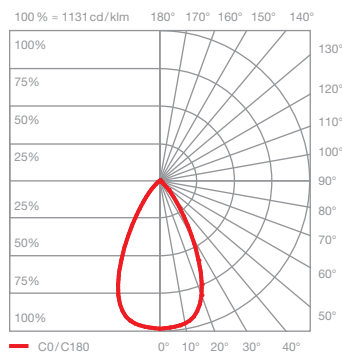
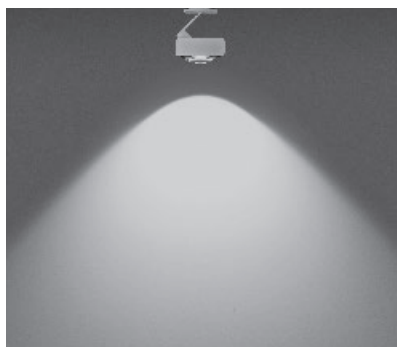

S 100 soft

scattered light with soft contour beam angle
(approx. 100°)

inserts: lens
satinised glass

luminous flux: perfect color 26 W 1260 lm
high flux 26 W 1720 lm

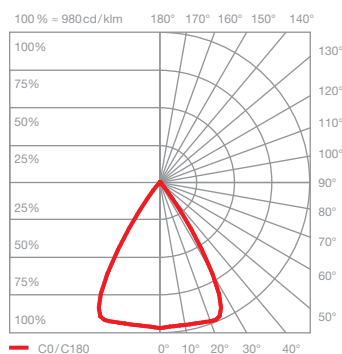
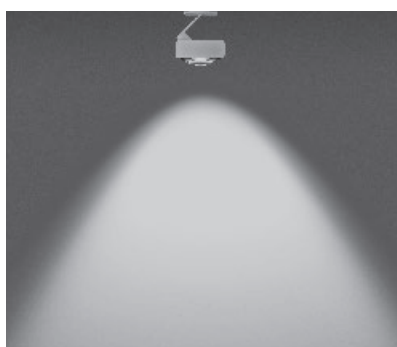

S 80 soft

scattered light with soft contour beam angle
(approx. 80°)

inserts: lens
soft edge glass

luminous flux: perfect color 26 W 1420 lm
high flux 26 W 1930 lm

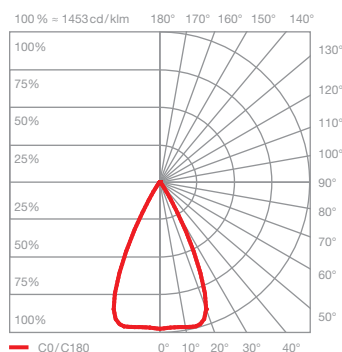

S 60 soft

scattered light with soft contour beam angle
(approx. 60°)

inserts: lens
small lens low
soft edge glass

luminous flux: perfect color 26 W 1610 lm
high flux 26 W 2200 lm

Più piano edge pro
Più lighting effects

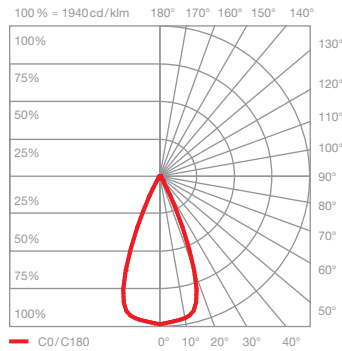
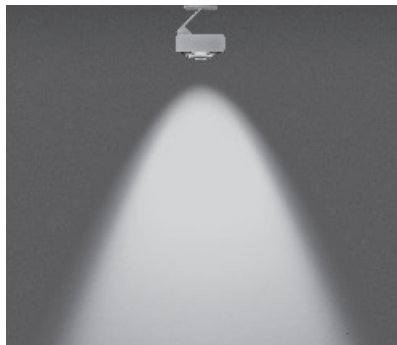

S40 soft

scattered light with soft contour beam angle (approx. 40°)

inserts: lens
small lens medium
soft edge glass

luminous flux: perfect color 26W 1680lm
high flux 26W 2300lm

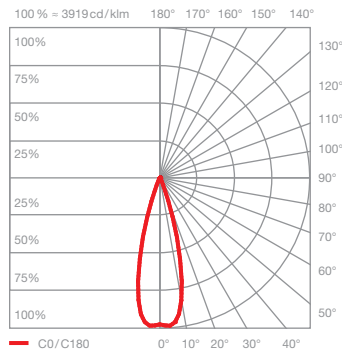

S30 soft

scattered light with soft contour beam angle (approx. 30°)

inserts: lens
small lens medium
fresnel lens

luminous flux: perfect color 26W 1650lm
high flux 26W 2250lm

Più piano edge pro Più R lighting effects

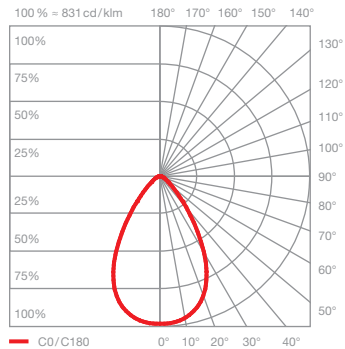

B diffus diffused light

inserts: cone glass
small lens low
satinised glass

luminous flux: perfect color 26W 1370lm
high flux 26W 1870lm

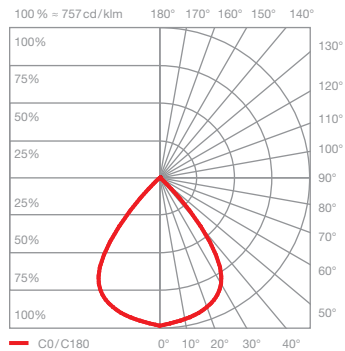
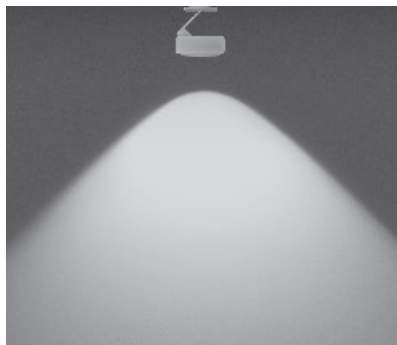

C 100 contour

scattered light with contour beam angle (approx. 100°)

inserts: cone glass
small lens low

luminous flux: perfect color 26W 1680lm
high flux 26W 2290lm

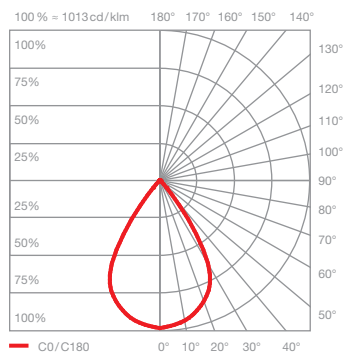
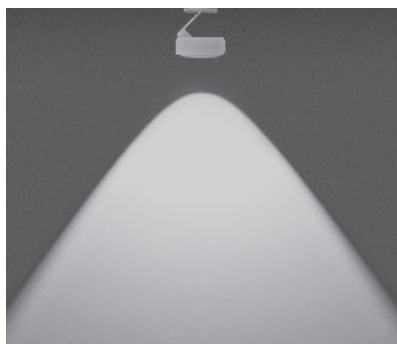

C 80 contour

scattered light with contour beam angle (approx. 80°)

inserts: cone glass
small lens medium

luminous flux: perfect color 26W 1810lm
high flux 26W 2460lm

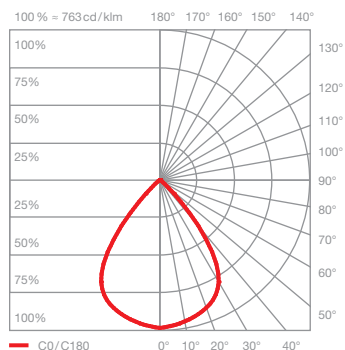
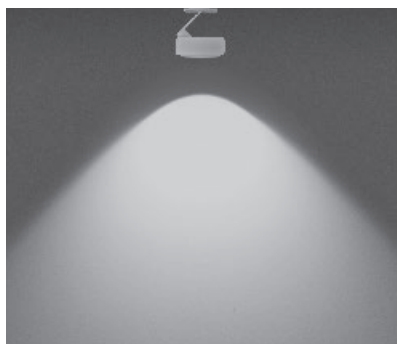

S 100 soft

scattered light with soft contour beam angle (approx. 100°)

inserts: cone glass
small lens low
soft edge glass

luminous flux: perfect color 26W 1520lm
high flux 26W 2070lm

Più piano edge pro Più R lighting effects

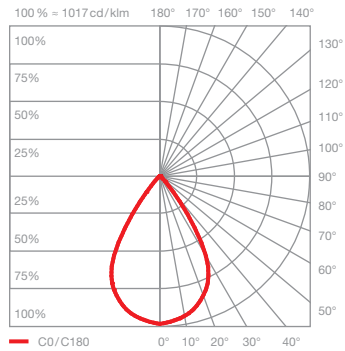
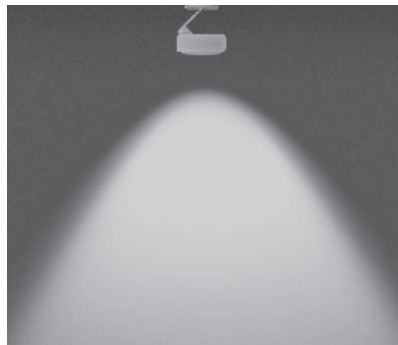

S80 soft

scattered light with soft contour beam angle (approx. 80°)

inserts: cone glass
small lens medium
soft edge glass

luminous flux: perfect color 26W 1690lm
high flux 26W 2310lm

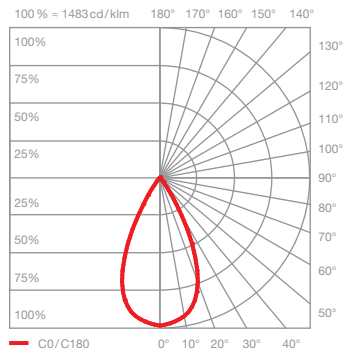
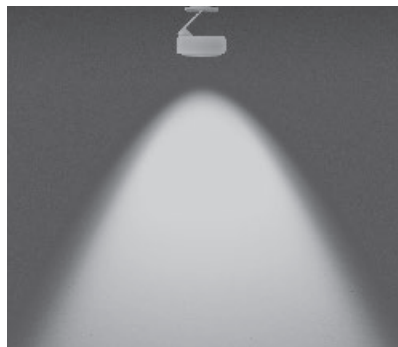

S60 soft

scattered light with soft contour beam angle (approx. 60°)

inserts: cone glass
small lens high
soft edge glass

luminous flux: perfect color 26W 1610lm
high flux 26W 2200lm

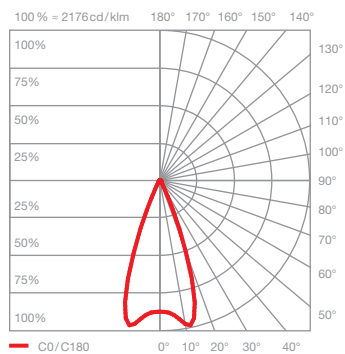
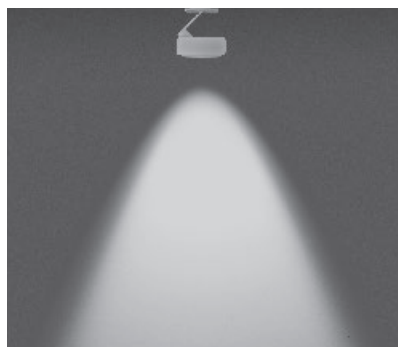

S40 soft

scattered light with soft contour beam angle (approx. 40°)

inserts: cone glass
small lens medium
fresnel lens

luminous flux: perfect color 26W 1600lm
high flux 26W 2190lm

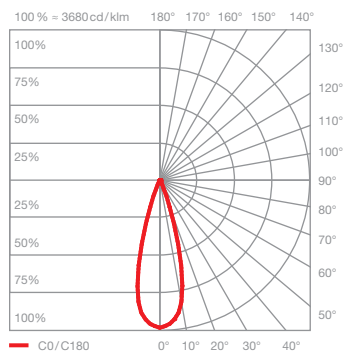

S30 soft

scattered light with soft contour beam angle (approx. 30°)

inserts: cone glass
small lens high
fresnel lens

luminous flux: perfect color 26W 1560lm
high flux 26W 2130lm